

CONTENT PAGE

UNIONS & COUPLINGS.....	3-20
SMS Union	3-5
Clamp Union	6-10
DIN Union	11-13
RJT Union	14-16
IDF Union	17-19
KF Vacuum Union.....	20
PIPE LINE FITTINGS	21-30
Elbow	21-22
Tee.....	23-24
Cross & Wye	25
Reducer	26-28
Hose Ferrule Adapter & Tube Cap.....	29
Pipe Support	30
VALVES	31-45
Level Gauge & Sample Cock Valve	31
Sanitary Three-Piece Body Ball Valve	32-33
Sanitary Two-Piece Body Ball Valve	34
Butterfly Valve	35-37
Non-Return / Check Valve.....	38-39
Diaphragm Valve.....	40
Pressure Relief Valve	41
Vacuum Relief Valve	42
Three Way Plug Valve	43
Inline Sight Glass.....	44

CONTENT PAGE

Tank Sight Glass	45
SANITARY CLEANING SPRAY BALLS	46
Static / Rotary Spray Ball.....	46
MANHOLE COVERS	47-48
Round Manhole Cover	47
Oval Manhole Cover	48
FLEXIBLE HOSES WITH CONNECTIONS & SPRAY GUNS	49-52
Food Grade Flexible Hose	49
Food Grade Hose Connections.....	50-51
Food Grade Water Spray Gun	52
SANITARY FILTERS	53-54
Sanitary Inline Filter	53
Sanitary Angled and Wye Filter.....	54
DAIRY TUBES	55
SMS/3A Dairy Tube	55
DIN Dairy Tube.....	55
WHAT IS SANITARY / FOOD GRADE STAINLESS STEEL?	56
RUBBER SEAL CHEMICAL & TEMPERATURE RESISTANCE	57

SMS UNION

The **SMS Union** (Swedish Metric Standard) is comprised of a round slotted nut, a liner, a male part and a gasket.

The liner and male part that come in contact with the product come in SS 304 and SS 316L, while the round nut is only available in SS 304.

Gasket Material: BUNA, EPDM, Viton, Teflon, Silicone.



SMS Union Nut

SIZE	øA	B	øD	L
1"	32	RD40x1/6	51	19
1.5"	48	RD60x1/6	74	23
2"	60.5	RD70x1/6	84	24
2.5"	74	RD85x1/6	100	28
3"	87	RD98x1/6	114	30
4"	113	RD125x1/4	138	31
4B"	117	RD132x1/6	150	31

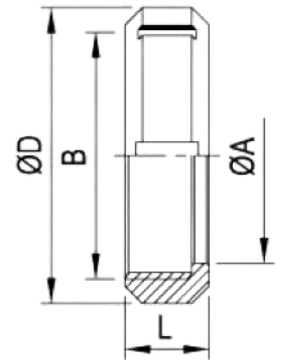

SMS Union Blank Nut with Chain

Size	B	øD	L
1"	RD40x1/6	51	19
1.5"	RD60x1/6	74	23
2"	RD70x1/6	84	24
2.5"	RD85x1/6	100	28
3"	RD98x1/6	114	30
4"	RD125x1/4	138	31
4B"	RD132x1/6	150	45

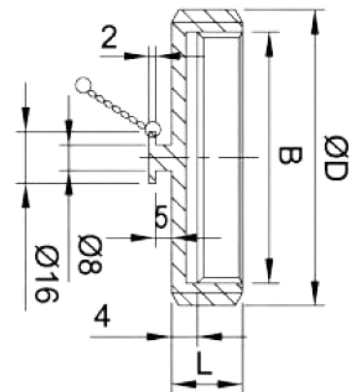

SMS UNION

SMS Union Liner

SIZE	ϕA	ϕB	ϕD	L
1"	22.5	25.4	35.5	11
1.5"	35.5	38.1	55	16
2"	48.5	50.8	65	17
2.5"	60.5	63.5	80	17
3"	72	76.2	93	19
4"	97.6	101.6	118	19
4B"	98.5	102.5	127	19

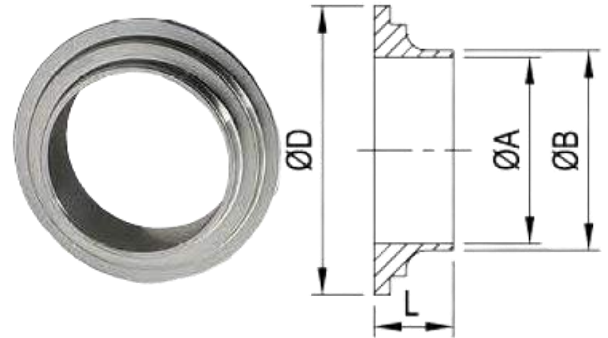

SMS Union Male Part

SIZE	ϕA	ϕB	ϕD	L
1"	22.5	25.4	RD40x1/6	18
1.5"	35.5	38.1	RD60x1/6	21
2"	48.5	50.8	RD70x1/6	21
2.5"	60.5	63.5	RD85x1/6	23
3"	72	76.2	RD98x1/6	23
4"	97.6	101.6	RD125x1/4	26
4B"	98.5	102.5	RD132x1/6	26

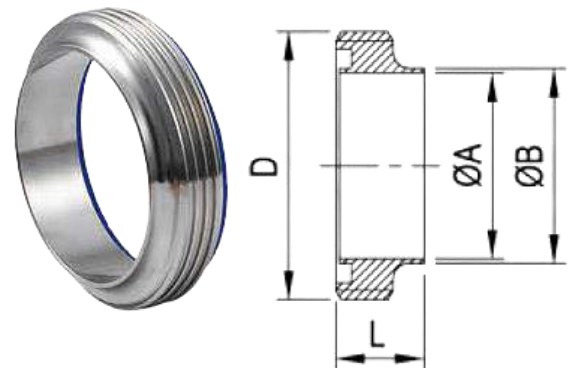

SMS UNION

SMS Union Blank

SIZE	ϕA	ϕB	ϕC	L
1"	32	35.5	3.5	7.5
1.5"	48	55	5	9
2"	60	65	5	10
2.5"	73.5	80	5	10
3"	86	93	5	11
4"	112	118	6	11
4B"	116	128	6	11

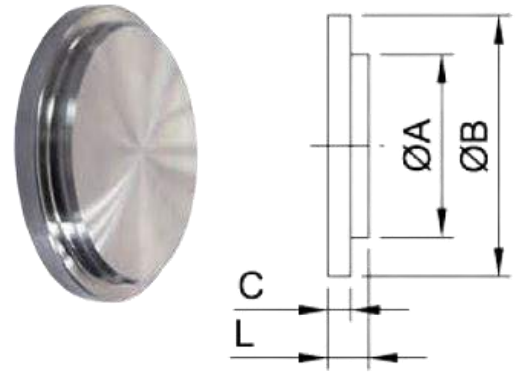

SMS Union Gasket (L Shape)

Size	ϕA	ϕB	ϕC
1"	22.8	25.1	31.8
1.5"	35.8	38.1	47.8
2"	48.8	51.1	60.8
2.5"	61	63.6	73.3
3"	73.4	76.1	85.8
4"	100.5	104	115.7
4B"	100.5	104	115.7

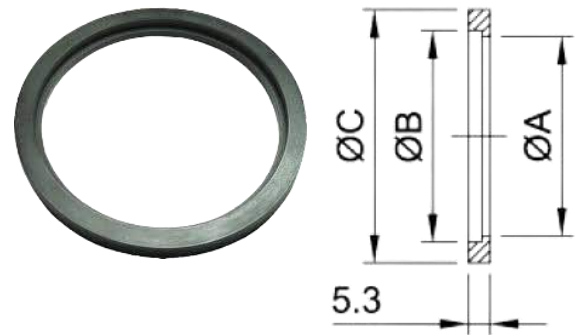

CLAMP UNION

The **Clamp Union** is comprised of a clamp ring, two ferrules, and a gasket. They come in 3A and DIN Standard.

The ferrules that come in contact with the product come in SS 304 and SS 316L, while the clamp ring is only available in SS 304.

Gasket Material: BUNA, EPDM, Viton, Teflon, Silicone.

The easiest way to identify a Clamp Union is by its **+ Shape Gasket**.

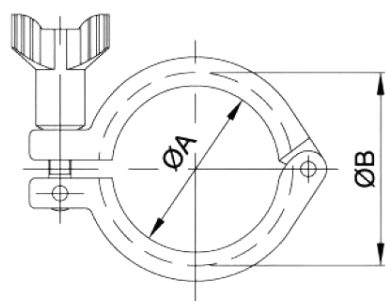

Clamp Ring (3A/SMS)

Size	ØA	ØB
0.5" - 0.75"	20.0	28.0
1" - 1.5"	44.4	53.6
2"	57.8	67
2.5"	71.4	80.6
3"	84.0	94.2
3.5"	99.0	109.2
4"	110.0	122.2
4.5"	123	133.2
6"	155.4	170.4
8"	205.0	220.0
10"	257.0	272.0
12"	308.0	323.0

Clamp Ring (DIN)

Size	ØA	ØB
DN 10	27.2	37.0
DN 15	44.5	37.0
DN 20	57	37.0
DN 25	44.4	53.6
DN 32	44.4	53.6
DN 40	44.4	53.6
DN 50	57.8	67.0
DN 65	84	94.2
DN 80	99	109.0
DN 100	110	122.2
DN 125	144	159.0
DN 150	172	187.0
DN 200	222.5	237.0
DN 250	257.0	272.0
DN 300	308.0	323.0

CLAMP UNION

Ferrule (3A/SMS)

SIZE	øA	øB	øC	L(Short)	L (Long)
0.5"	9.4	12.7	25	12.7	28.6
0.75"	15.75	19.05	25	12.7	28.6
1"	22.1	25.4	50.5	12.7	28.6
1.25	28.4	31.75	50.5	12.7	28.6
1.5"	34.8	38.1	50.5	12.7	28.6
2"	47.5	50.8	64	12.7	28.6
2.5"	60.2	63.5	77.5	12.7	28.6
3"	72.9	76.1	91	12.7	28.6
3.5"	84.9	88.9	106	15.9	28.6
4"	97.4	101.6	119	15.9	28.6
4.5	110.3	114.3	130	21.5	28.6 or 38.1
5"	123	127	144.5	21.5	28.6 or 38.1
5.5"	133.7	139.7	155	21.5	28.6 or 38.1
6"	146.86	152.5	166.87	21.5	28.6 or 38.1
8"	197.66	203.3	217.67	21.5	28.6 or 38.1
10"	247.2	254	268.47	21.5	28.6 or 38.1
12"	298	304.8	319.27	21.5	28.6 or 38.1



Ferrule (DIN)

SIZE	øA	øB	øC	L
DN 10	10	13	34	12.7 / 21.5
DN 15	16	19	34	12.7 / 21.5
DN 20	20	23	34	12.7 / 21.5
DN 25	26	29	50.5	12.7 / 21.5
DN 32	32	35	50.5	12.7 / 21.5
DN 40	38	41	50.5	12.7 / 21.5
DN 50	50	53	64	12.7 / 21.5
DN 65	66	70	91	12.7 / 21.5
DN 80	81	85	106	12.7 / 21.5
DN 100	100	104	119	12.7 / 28.6
DN 125	125	129	155	12.7 / 28.6
DN 150	150	154	183	12.7 / 28.6
DN 200	200	204	233.5	12.7 / 28.6
DN 250	250	254	268.5	12.7 / 28.6
DN 300	300	306	319.3	12.7 / 28.6

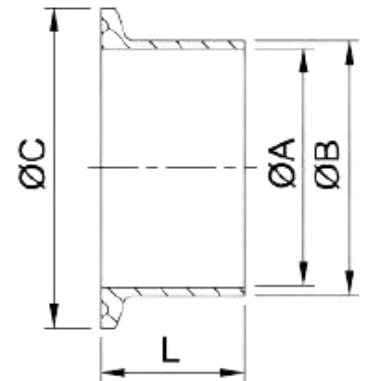

CLAMP UNION

Ferrule (ISO)

Size	ϕA	ϕB	ϕC	L
DN 25	30.5	33.7	50.5	28.6
DN 40	45.1	48.3	64	28.6
DN 50	56.3	60.3	77.5	28.6
DN 65	72.1	76.1	91	28.6
DN 80	84.3	88.9	106	28.6
DN 100	109.7	114.3	130	28.6

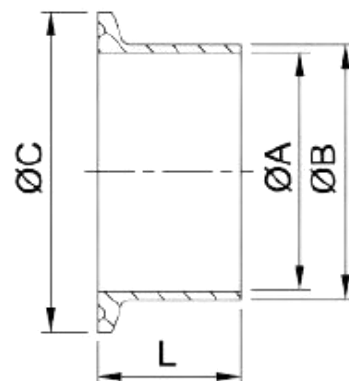

Ferrule Blank

3A	DIN	ϕA	L
0.5" 0.75"	-	25	6
-	DN10	34	6.3
-	DN15	34	6.3
-	DN20	34	6.3
1"	DN25	50.5	6.3
1.25"	DN32	50.5	6.3
1.5"	DN40	50.5	6.3
2"	DN50	64	6.3
2.5"	-	77.5	6.3
3"	DN65	91	6.3
3.5"	DN80	106	6.3
4"	DN100	119	7.9
4.5"	-	130	7.9
5"	-	144.5	10.0
5.5"	DN125	155	7.9
6"	-	166.8	11.1
-	DN150	183	11.1
8"	-	217.7	11.1
-	DN200	233.5	11.1
10"	DN250	268.5	11.1
12"	DN300	319.3	11.1

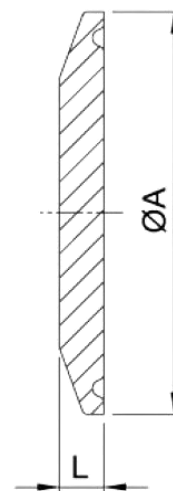

CLAMP UNION

Ferrule Gasket (Plain Type 13PG)

SIZE	ϕA	ϕB
0.5"	9.9	21.8
0.75"	16.3	21.8
1"	22.1	50.5
1.25"	28.4	50.5
1.5"	34.8	50.5
2"	47.5	64
2.5"	60.2	77.5
3"	72.9	91
3.5"	84.9	106
4"	97.4	119
4.5"	110.3	130
5"	123	144.5
5.5"	133.7	155
6"	146.86	166.87
8"	197.66	217.67
10"	247.2	268.47
12"	298	319.27

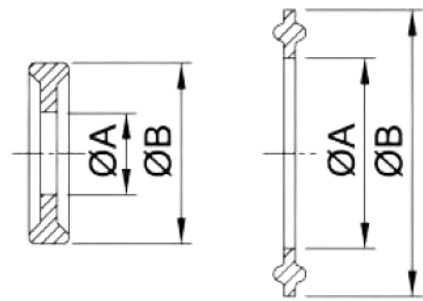

0.5" - 0.75"

1" - 12"

13PG

Ferrule Gasket (Flange Type 13FG)

SIZE	ϕA	ϕB
1"	22.1	52.7
1.5"	34.8	52.7
2"	47.5	66.2
2.5"	60.2	79.7
3"	72.9	93.2
4"	97.4	121.2
6"	146.86	169.1
10"	247.2	270.7
12"	298	321.5

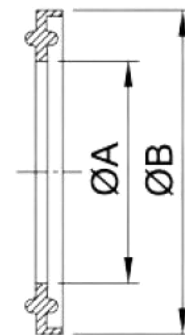

13FG

CLAMP UNION

DIN Ferrule Gasket (Plain Type 13PG)

SIZE	ϕA	ϕB
DN 10	10	34
DN 15	16	34
DN 20	20	34
DN 25	26	50.5
DN 32	32	50.5
DN 40	38	50.5
DN 50	50	64
DN 65	66	91
DN 80	81	106
DN 100	100	119
DN 125	125	155
DN 150	150	183
DN 200	200	233.5
DN 250	250	268.5
DN 300	300	319.3

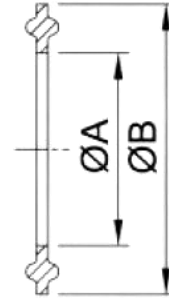

13PG

DIN UNION

The **DIN Union** (Deutsches Institut für Normung / German Institute for Standardization) is comprised of a round slotted nut, a liner, a male part, and a gasket.

The male part and liner that come in contact with the product come in SS 304 and SS 316L, while the round nut is only available in SS 304.

Gasket Material: BUNA, EPDM, Viton, Teflon, Silicone.

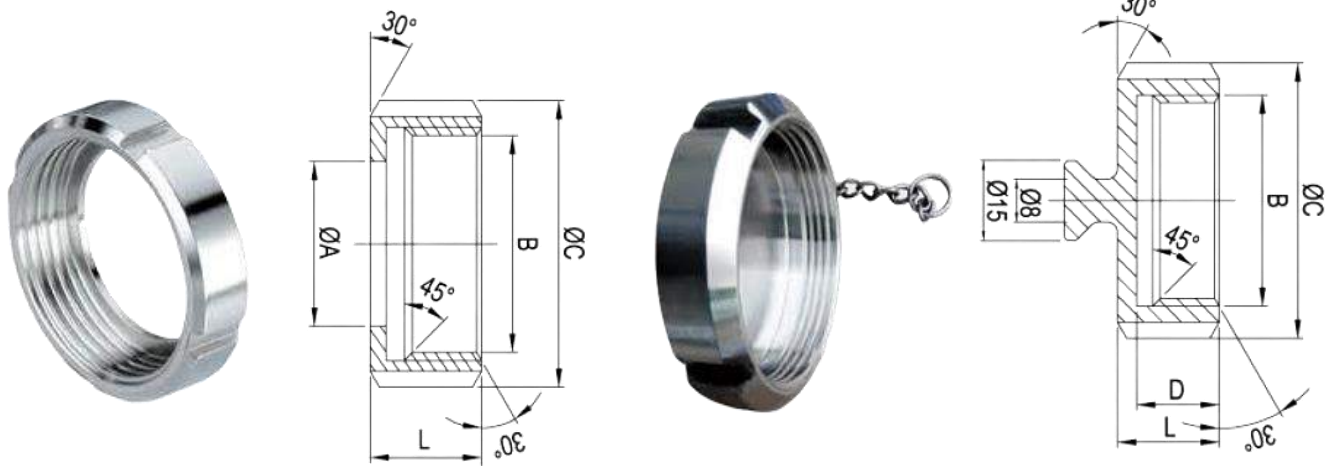

DIN Union Nut

DIN Union Blank Nut with Chain

SIZE	ØA	B	ØC	D	L	Slots
DN10	19	RD28x1/8	38	15	18	4
DN15	25	RD34x1/8	44	15	18	4
DN20	31	RD44x1/6	54	17	21	4
DN25	36	RD52x1/6	63	18	21	4
DN32	42	RD58x1/6	70	18	21	4
DN40	49	RD65x1/6	78	18	21	4
DN50	62	RD78x1/6	92	19	22	4
DN65	80	RD95x1/6	112	21	25	6
DN80	94	RD110x1/4	127	25	30	6
DN100	115	RD130x1/4	148	26	31	6
DN125	138	RD160x1/4	178	30	35	6
DN150	164	RD190x1/4	210	34	40	6

DIN UNION

DIN Union Liner

DIN/SMS	øA	øB	øC	L
10	10	13	22.5	17
15	16	19	28.5	17
20	20	23	36.5	18
25 / 1"	26 / 22.4	29 / 25.4	44	22
32	32	35	50	25
40 / 1.5"	38 / 35.1	41 / 38.1	56	26
50 / 2"	50 / 47.8	53 / 50.8	68.5	28
65 / 2.5"	66 / 60.5	70 / 63.5	86	32
80 / 3"	81 / 73.2	85 / 76.2	100	37
100 / 4"	100 / 97.6	104 / 101.6	121	44
125	125	129	150	34
150	150	154	176	37

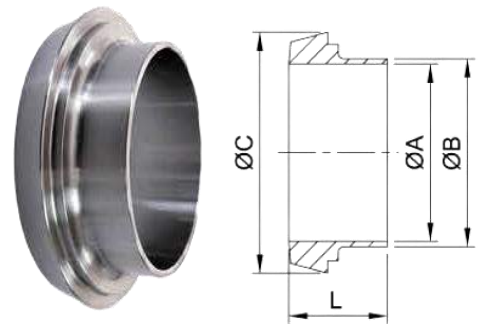

DIN Union Male Part

DIN/SMS	øA	øB	øC	L
10	10	13	RD28x1/8	21
15	16	19	RD34x1/8	21
20	20	23	RD44x1/6	24
25 / 1"	26 / 22.4	29 / 25.4	RD52x1/6	29
32	32	35	RD58x1/6	32
40 / 1.5"	38 / 35.1	41 / 38.1	RD65x1/6	33
50 / 2"	50 / 47.8	53 / 50.8	RD78x1/6	35
65 / 2.5"	66 / 60.5	70 / 63.5	RD95x1/6	40
80 / 3"	81 / 73.5	85 / 76.2	RD110x1/4	45
100 / 4"	100 / 97.6	104 / 101.6	RD130x1/4	54
125	125	129	RD160x1/4	46
150	150	154	RD190x1/4	50

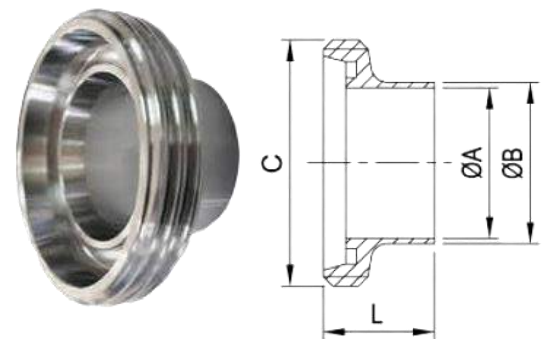

DIN UNION

DIN Union Blank

Size	ϕA	ϕB	L
10	18	22	9
15	24	28	9
20	30	36	11
25	35	44	13
32	41	50	13
40	48	56	13
50	61	68	14
65	79	86	16
80	93	100	16
100	114	121	20
125	137	150	22
150	163	176	24

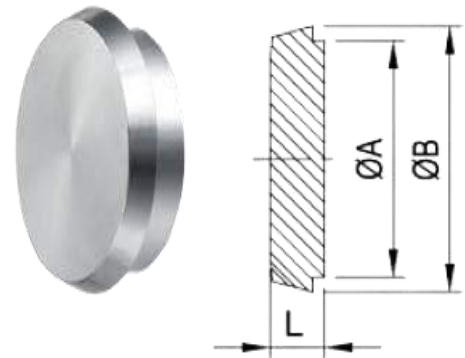

DIN Union Gasket (D shape)

Size	ϕA	ϕB	L
10	12	20	4.5
15	18	26	4.5
20	23	33	4.5
25	30	40	5
32	36	46	5
40	42	52	5
50	54	64	5
65	71	81	5
80	85	95	5
100	104	114	5
125	130	142	7
150	155	167	7

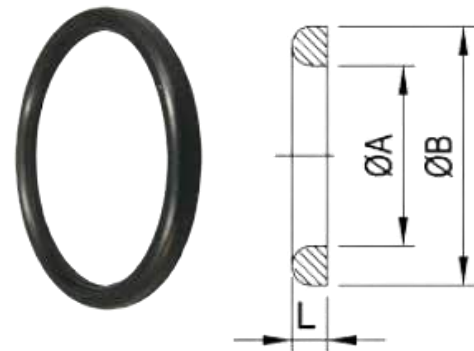

RJT UNION

The **RJT Union** (Ring Joint Type) is comprised of a round slotted nut, a liner, a male part, and a gasket.

The male part and liner that come in contact with the product come in SS 304 and SS 316L, while the round nut is only available in SS 304.

Gasket Material: BUNA, EPDM, Viton, Teflon, Silicone.

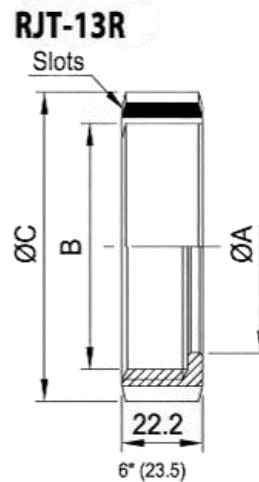

RJT Union Nut

SIZE	ØA	B	ØC	L	L1	Slots
0.5"	14.5	19.6x10 TPI WHIT	-	16	-	-
0.75"	21	26.2x10 TPI WHIT	-	16	-	-
1"	33.45	42.266x8 TPI WHIT	58.5	22.2	23.5	4
1.5"	46	54.966x8 TPI WHIT	74	22.2	23.5	4
2"	58.67	67.92x6 TPI WHIT	85.5	22.2	23.2	6
2.5"	71.4	80.62x6 TPI WHIT	98.5	22.2	23.5	6
3"	84.1	93.32x6 TI WHIT	111.6	22.2	23.5	8
4"	109.7	118.72x6 TPI WHIT	138	22.2	23.5	8
6"	163	169.52x6 TPI WHIT	197	24	-	10

RJT UNION

RJT Union Liner

SIZE	øA	øB	øC	L
0.5"	9.6	14	18	11.4
0.75"	16	20	23.1	11.4
1"	22.2	25.4	41.3	19.5
1.5"	34.8	38.1	54	19.5
2"	47.5	50.8	66.7	19.5
2.5"	60.2	63.5	79.4	19.5
3"	72.9	76.2	92.1	19.5
4"	97.6	101.6	117.5	19.5
6"	148	152.4	169.1	23.5

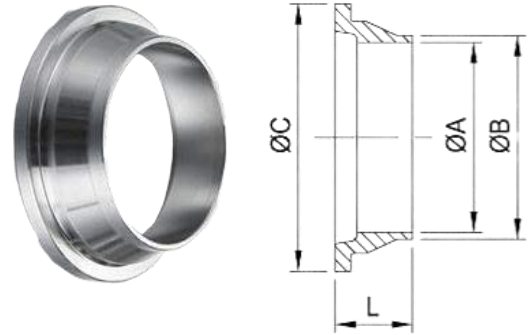

RJT Union Male Part

SIZE	øA	øB	øC	L
0.5"	9.6	13.7	21.2x10T WHIT	16.5
0.75"	16	20	27.6x10T WHIT	16.5
1"	22.1	25.4	45.72x8T WHIT	27
1.5"	34.8	38.1	58.42x8T WHIT	27
2"	47.5	50.8	72.72x6T WHIT	27
2.5"	60.2	63.5	85.42x6T WHIT	27
3"	72.9	76.2	98.12x6T WHIT	27
4"	97.6	101.6	123.52x6T WHIT	27
6"	100	104	123.52x6T WHIT	27

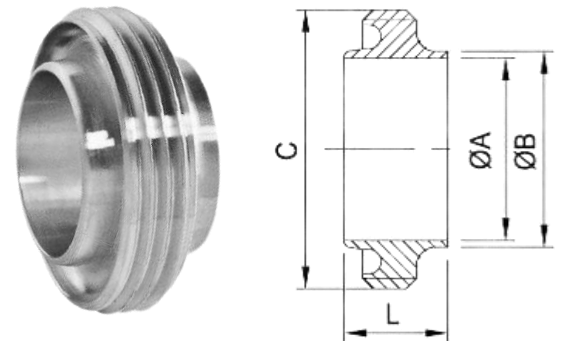

RJT UNION

RJT Union Blank

SIZE	ϕA	ϕB	ϕC	L
1"	37.8	32.5	41.3	9
1.5"	40.5	45.2	54	9
2"	53.2	57.9	66.7	9
2.5"	65.9	70.6	79.4	9
3"	78.2	83.3	92.1	9
4"	104	108.7	117.5	9
104	104	108.7	117.5	9

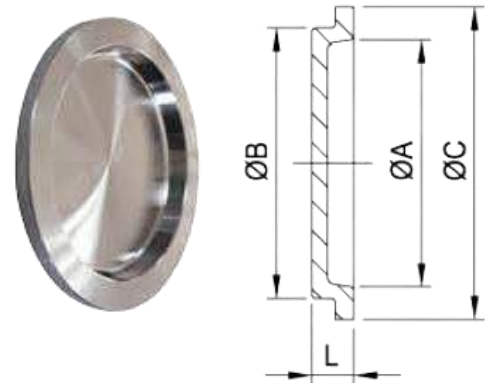

RJT Union Gasket

Size	ϕA	ϕB	ϕC
1"	33.3	6.6	3.2
1.5"	46	6.6	3.2
2"	58.7	6.6	3.2
2.5"	71.4	6.6	3.2
3"	84.1	6.6	3.2
4"	109.5	6.6	3.2
6"	162.6	6.6	3.2

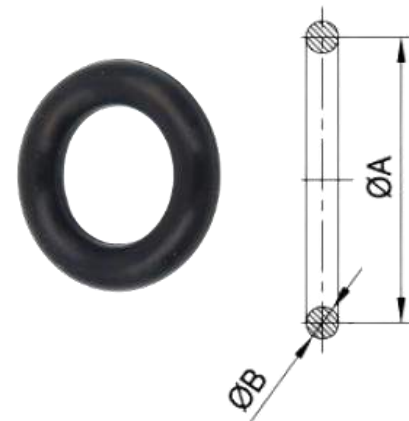

IDF UNION

The **IDF Union** (International Dairy Federation) is comprised of a round slotted nut, a liner, a male part, and a gasket.

The male part and liner that come in contact with the product come in SS 304 and SS 316L, while the round nut is only available in SS 304.

Gasket Material: BUNA, EPDM, Viton, Teflon, Silicone.

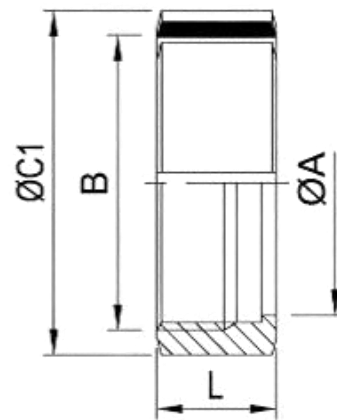

IDF Union Nut

SIZE	ØA	B	ØC	ØC1	L
1"	30.5	34.34x8T ACME	46	48	30
1.5"	43.5	47.86x8T ACME	60	64	30
2"	57	61.37x8T ACME	75	77	30
2.5"	70.7	74.88x8T ACME	90	91	30
R 3"	83.3	88.4x8T ACME	106	106	30
H 3"	83.3	88.4x8T ACME	105	105	30
R 4"	112	115.41x8T ACME	135	135	34.9
H 4"	112	122.05x6T ACME	133	133	34.9

IDF UNION

IDF Union Liner

SIZE	ϕA	ϕB	ϕC	L
1"	22.6	25.6	33.8	21.5
1.5"	35.6	38.6	47	21.5
2"	48.6	51.6	60.5	21.5
2.5"	60.3	61.1	74	21.5
3"	72.9	76.7	87.5	21.5
R 4"	97.6	101.6	120.6	30
H 4"	97.6	102.5	114.1	21.5

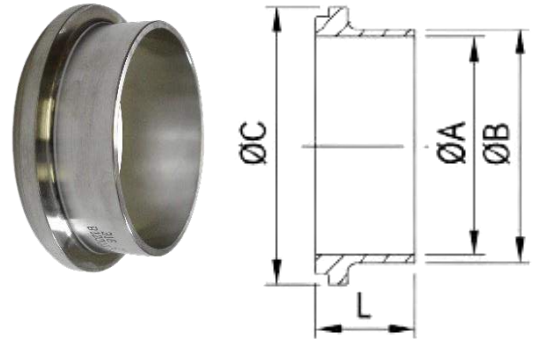

IDF Union Male Part

SIZE	ϕA	ϕB	ϕC	L
1"	22.1	25.4	37.13x8T ACME	21.5
1.5"	34.8	38	50.65x8T ACME	21.5
2"	47.5	51	64.16x8T ACME	21.5
2.5"	60.2	63.5	77.76x8T ACME	21.5
3"	72.9	76.2	91.19x8T ACME	21.5
R 4"	97.6	101.6	118.2x8T ACME	30
H 4"	97.6	102.5	125.9x6T ACME	21.5

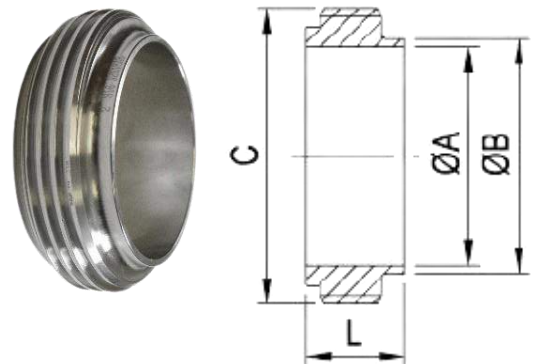

IDF UNION

IDF Union Blanks

Size	ϕA	ϕB	L
1"	29.2	33.8	10.5
1.5"	42.7	47	10.5
2"	56.2	60.5	10.5
2.5"	69.9	74	10.5
3"	82.6	87.5	10.5
R 4"	111.1	114.1	12.6
H 4"	111.1	120.6	12.6

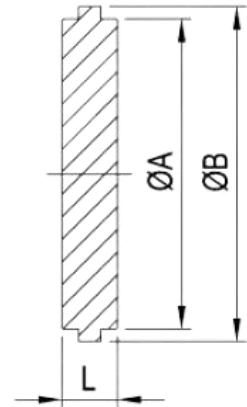

IDF Union Gasket

SIZE	ϕA	ϕB
1"	23	32.5
1.5"	36	46
2"	49	59.5
2.5"	60.7	73.2
3"	73.2	86.5
4"	98	113
6"	98	119.6

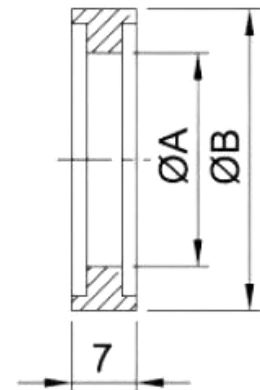

KF VACUUM UNION

KF Union Aluminum Clamp Ring

Size	ϕA	ϕB	L
KF10/16	35	45	62
KF25	45	55	73
KF40	60	70	86.1
KF50	80	96	123

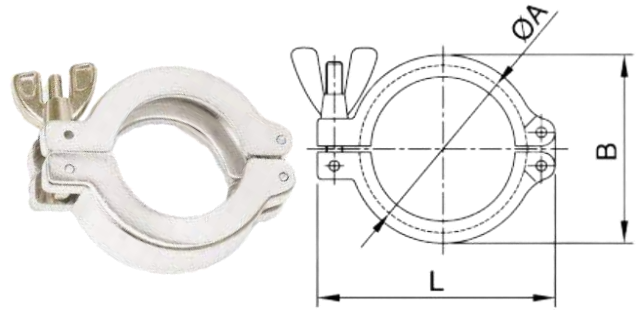

KF Union Flange

Size	ϕA	ϕB	ϕC	ϕD	L
KF10	9.4 (10)	12.7 (14)	12.2	30	12.7 or 30
KF16	15.7 (16)	19.06 (20)	17.3	30	
KF25	22.1 (25)	25.4 (28)	26.2	40	
KF40	33.8 (40)	38.1 (44.5)	41.1	55	
KF50	46.5 (50)	50.8 (54)	52.3	75	

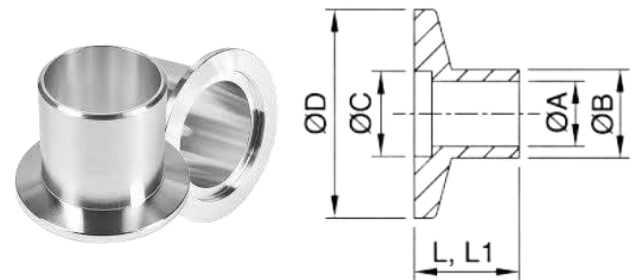

KF Union Blank

Size	ϕC	ϕD	L
KF10	12.2	30	5.1
KF16	17.3	30	5.1
KF25	26.2	40	5.1
KF40	41.1	55	5.1
KF50	52.3	75	5.1

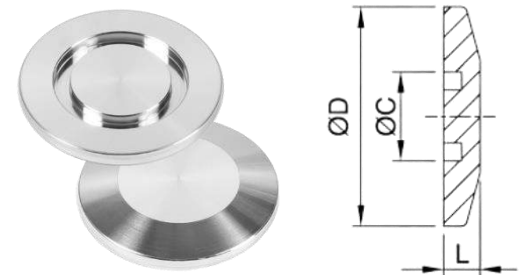

KF Union Centering Ring with Seal

SIZE	ϕA	ϕB	C	D
KF10	10	12	8	3.9
KF16	16	17	8	3.9
KF25	25	26	8	3.9
KF40	40	41	8	3.9
KF50	50	52	8	3.9

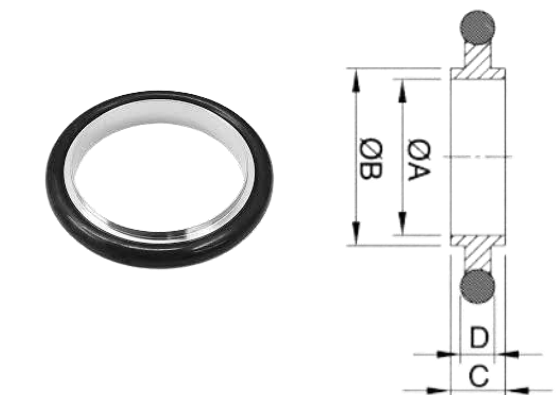

ELBOW

45 Deg Elbow

Size	øD	L	T
0.5"	12.7	13.16	1.65
0.75"	19.05	23.8	1.65
1"	25.4	15.8	1.65
1.5"	38.1	23.8	1.65
2"	50.8	31.75	1.65
2.5"	63.5	39.6	1.65
3"	76.2	47.6	1.65
4"	101.6	63.5	2.1

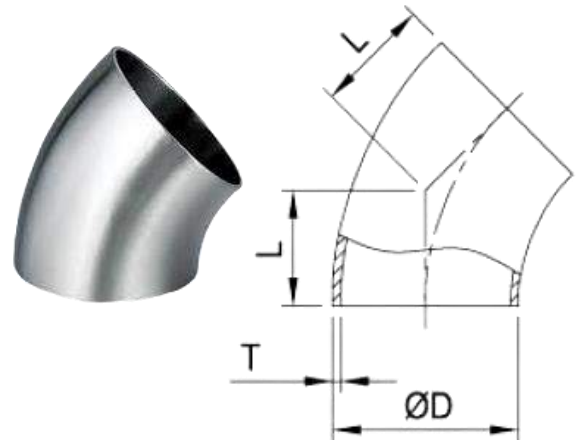

90 Deg Elbow

Size	øD	L	T
0.5"	12.7	13.16	1.65
0.75"	19.05	23.8	1.65
1"	25.4	15.8	1.65
1.5"	38.1	23.8	1.65
2"	50.8	31.75	1.65
2.5"	63.5	39.6	1.65
3"	76.2	47.6	1.65
4"	101.6	63.5	2.1

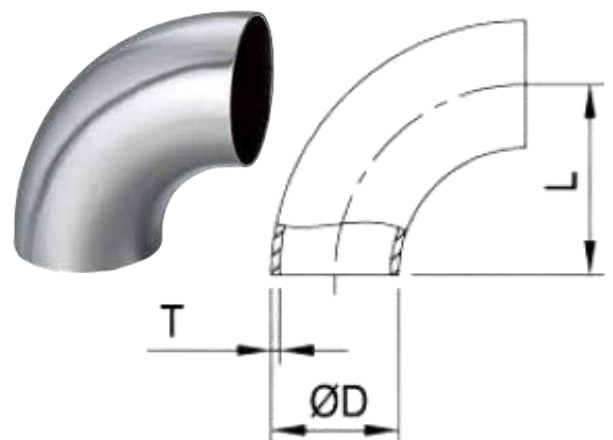

90 Deg Long Elbow

Size	øD	L	T
0.5"	12.7	45	1.65
0.75"	19.05	60	1.65
1"	25.4	52.4	1.65
1.5"	38.1	74.6	1.65
2"	50.8	103.2	1.65
2.5"	63.5	131.8	1.65
3"	76.2	160.3	1.65
4"	101.6	211.1	2.1

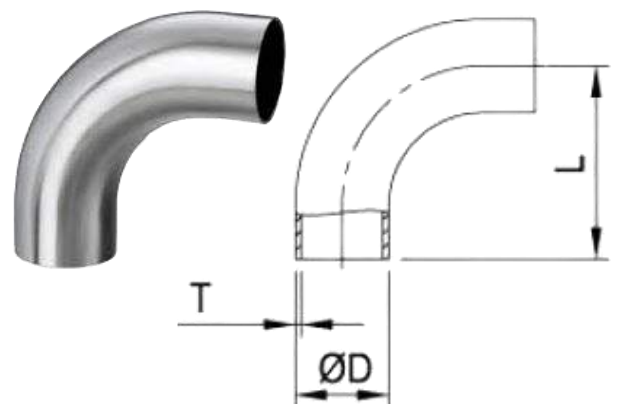

ELBOW

90 Deg Elbow with Ferrule Ends

Size	øD	L	T
0.5"	12.7	41.3	1.65
0.75"	19.05	41.3	1.65
1"	25.4	50.8	1.65
1.5"	38.1	69.9	1.65
2"	50.8	88.9	1.65
2.5"	63.5	107.95	1.65
3"	76.2	127	1.65
4"	101.6	168.2	2.1

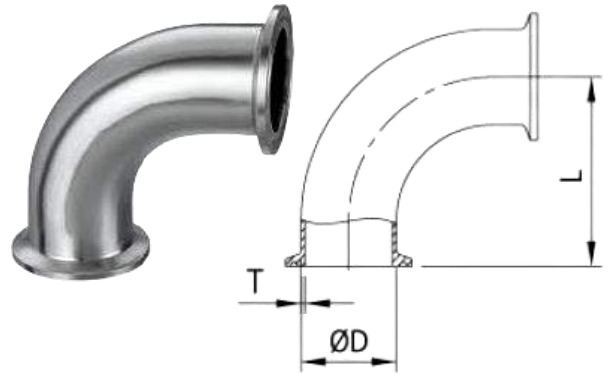

DIN 90 Deg Elbow

Size	øD	L	T
DN 10	13	26	1.5
DN 15	19	35	1.5
DN 20	23	40	1.5
DN 25	29	50	1.5
DN 32	35	55	1.5
DN 40	41	60	1.5
DN 50	53	70	1.5
DN 65	70	80	2
DN 80	85	90	2
DN 100	104	100	2
DN 125	129	187.5	2
DN 150	154	225	2
DN 200	204	301	2
DN 250	254	375	2
DN 300	306	300	3

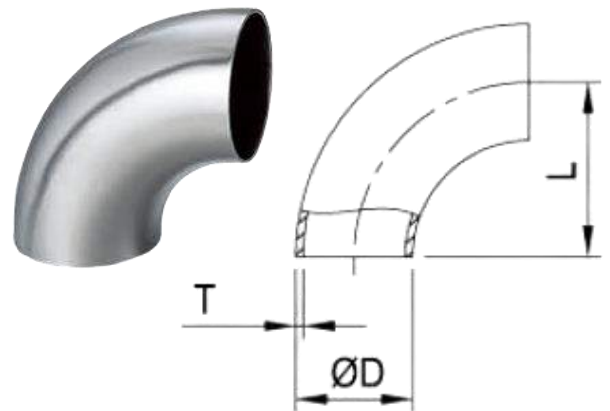

TEE

Equal Tee

SIZE	øD	L	L1	T
0.5"	12.7	38.1	19.05	1.65
0.75"	19.05	57.2	28.6	1.65
1"	25.4	57.2	28.6	1.65
1.5"	38.1	84.2	42.1	1.65
2"	50.8	104.8	52.4	1.65
2.5"	63.5	119.0	59.5	1.65
3"	76.2	131.8	65.9	1.65
4"	101.6	174.6	87.3	2.1



Long Equal Tee

SIZE	øD	L	L1	T
0.5"	12.7	95.2	47.6	1.65
0.75"	19.05	95.2	47.6	1.65
1"	25.4	95.2	47.6	1.65
1.5"	38.1	114.4	57.2	1.65
2"	50.8	152.4	76.2	1.65
2.5"	63.5	152.4	76.2	1.65
3"	76.2	165.2	82.6	1.65
4"	101.6	196.8	98.4	2.1

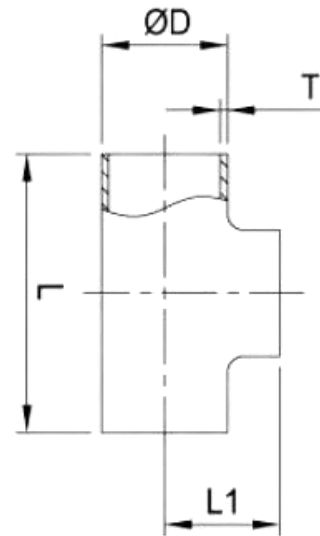

Equal Tee with Ferrule Ends

SIZE	øD	L	L1	T
0.5"	12.7	63.5	31.75	1.65
0.75"	19.05	120.6	60.3	1.65
1"	25.4	120.6	60.3	1.65
1.5"	38.1	139.8	69.9	1.65
2"	50.8	177.8	88.9	1.65
2.5"	63.5	177.8	88.9	1.65
3"	76.2	190.6	95.3	1.65
4"	101.6	228.4	114.2	2.1

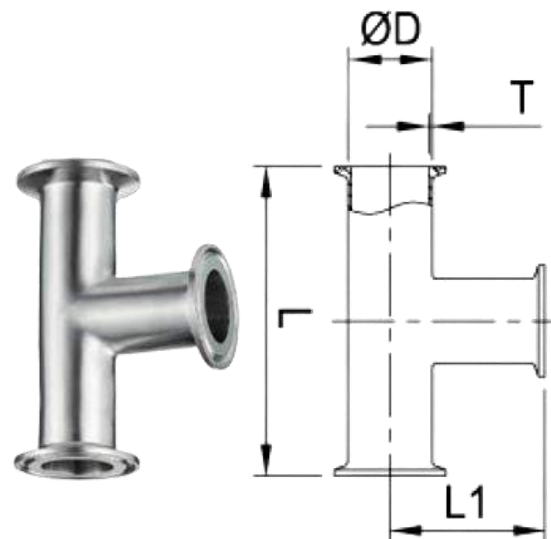

TEE

Reducing Tee

Size	øD	ød	L	L1	T
1.5"x1"	38.1	25.4	84.2	34.9	1.65
2"x1"	50.8	25.4	104.8	41.3	1.65
2"x1.5"	50.8	38.1	104.8	48.4	1.65
2.5"x1"	63.5	25.4	119	47.63	1.65
2.5"x1.5"	63.5	38.1	119	54.75	1.65
2.5"x2"	63.5	50.8	119	58.7	1.65
3"x1"	76.2	25.4	131.8	54	1.65
3"x1.5"	76.2	38.1	131.8	65.1	1.65
3"x2"	76.2	50.8	131.8	65.1	1.65
3"x2.5"	76.2	63.5	131.8	65.9	2
4"x1"	101.6	25.4	174.6	66.7	2
4"x1.5"	101.6	38.1	174.6	108.0	2
4"x2"	101.6	50.8	174.6	108.0	2
4"x2.5"	101.6	63.5	174.6	108.0	2
4"x3"	101.6	76.2	174.6	108.0	2

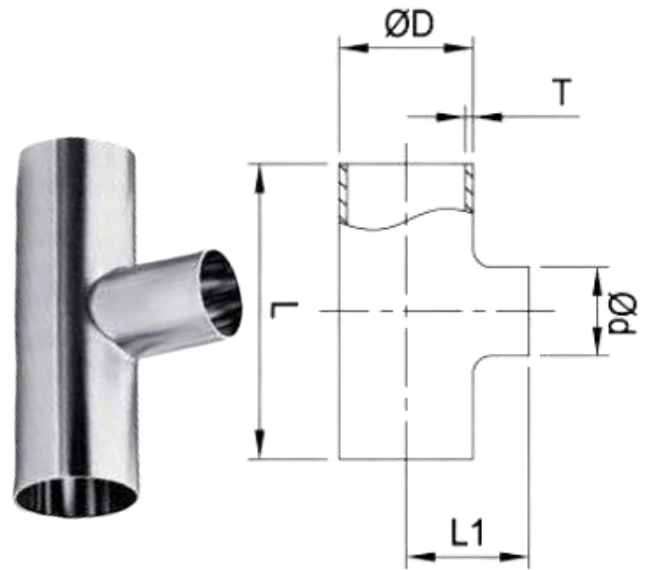

DIN Equal Tee

SIZE	øD	L	L1	T
DN 10	13	54	26	1.5
DN 15	19	70	35	1.5
DN 20	23	94	47	1.5
DN 25	29	100	50	1.5
DN 32	35	110	55	1.5
DN 40	41	120	60	1.5
DN 50	53	140	70	1.5
DN 65	70	160	80	2
DN 80	85	180	90	2
DN 100	104	200	100	2
DN 125	129	375	187.5	2
DN 150	154	450	225	2
DN 200	204	600	300	2
DN 250	254	750	375	2
DN 300	306	750	375	3

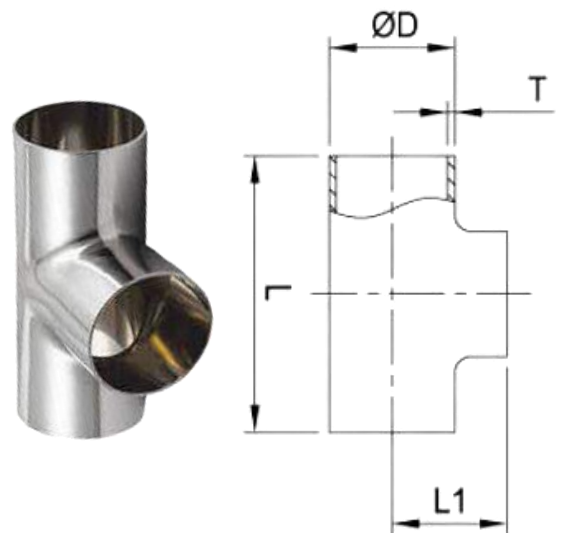

CROSS & WYE

Equal Short Cross

SIZE	øD	L	L1	T
1"	25.4	57.2	28.6	1.65
1.5"	38.1	84.2	42.1	1.65
2"	50.8	104.8	52.4	1.65
2.5"	63.5	119.0	59.5	1.65
3"	76.2	131.8	65.9	1.65
4"	101.6	174.6	87.3	2

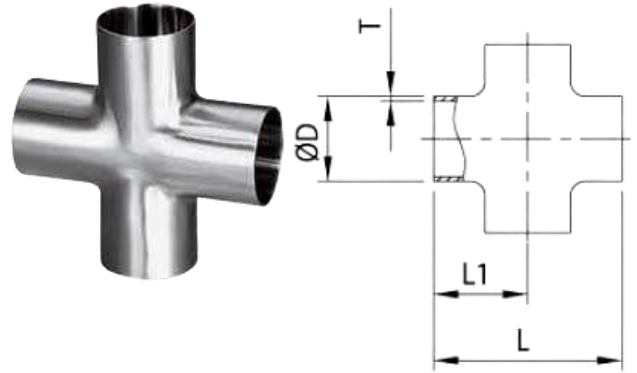

True Wye

SIZE	A
0.5"	50.8
0.75"	50.8
1"	76.2
1.5"	76.2
2"	101.6
2.5"	127
3"	152.4
4"	203.2

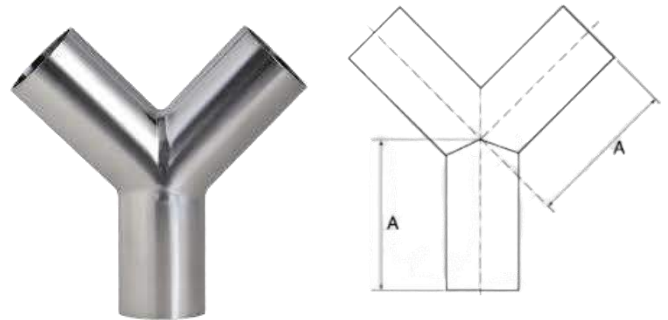

Lateral Wye

SIZE	A	B	C
0.5"	152.4	127	25.4
0.75"	152.4	127	25.4
1"	152.4	127	25.4
1.5"	187.3	173.1	30.2
2"	222.2	180.9	41.3
2.5"	254	215.9	38.1
3"	273.1	225.4	47.6
4"	325.5	273.1	52.4

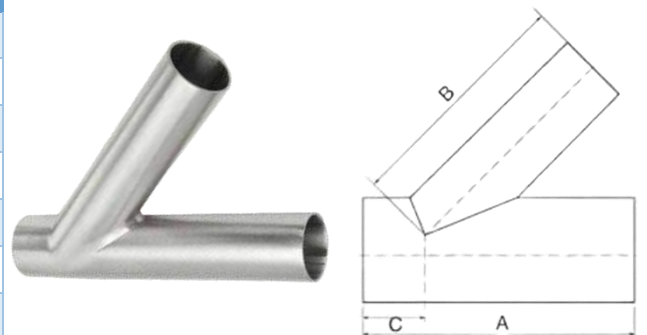

CONCENTRIC REDUCER

Concentric Reducer without Straight End

SIZE	øD	ød	L	T
0.75"x0.5"	19.05	12.7	50.8	1.65
1"x0.5"	25.4	12.7	50.8	1.65
1.5"x0.5"	38.1	12.7	101.6	1.65
2"x0.5"	50.8	12.7	152.4	1.65
1"x0.75"	25.4	19.05	25.4	1.65
1.5"x0.75"	38.1	19.05	76.2	1.65
1.5"x1"	38.1	25.4	50.8	1.65
2"x1"	50.8	25.4	101.6	1.65
2"x1.5"	50.8	38.1	50.8	1.65
2.5"x1"	63.5	25.4	152.4	1.65
2.5"x1.5"	63.5	38.1	101.6	1.65
2.5"x2"	63.5	50.8	50.8	1.65
3"x1"	76.2	25.4	203.2	1.65
3"x1.5"	76.2	38.1	152.4	1.65
3"x2"	76.2	50.8	101.6	1.65
3"x2.5"	76.2	63.5	50.8	1.65
4"x1.5"	101.6	38.1	254	2
4"x2"	101.6	50.8	203.2	2
4"x2.5"	101.6	63.5	152.4	2
4"x3"	101.6	76.2	101.6	2
6"x2"	152.4	50.8	406.4	2
6"x3"	152.4	76.2	304.8	2
6"x4"	152.4	101.6	203.2	2

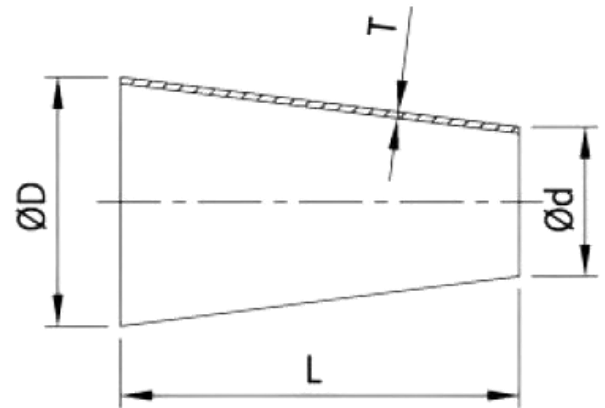

ECCENTRIC REDUCER

Eccentric Reducer without Straight End

SIZE	ϕD	ϕd	L	T
0.75"x0.5"	19.05	12.7	25.4	1.65
1"x0.5"	25.4	12.7	50.8	1.65
1.5"x0.5"	38.1	12.7	101.6	1.65
2"x0.5"	50.8	12.7	152.4	1.65
1"x0.75"	25.4	19.05	25.4	1.65
1.5"x0.75"	38.1	19.05	76.2	1.65
2"x0.75"	50.8	19.05	127	1.65
1.5"x1.0"	38.1	25.4	50.8	1.65
2"x1"	50.8	25.4	101.6	1.65
2"x1.5"	50.8	38.1	50.8	1.65
2.5"x1"	63.5	25.4	152.4	1.65
2.5"x1.5"	63.5	38.1	101.6	1.65
2.5"x2"	63.5	50.8	50.8	1.65
3"x1"	76.2	25.4	203.2	1.65
3"x1.5"	76.2	38.1	152.4	1.65
3"x2"	76.2	50.8	101.6	1.65
3"x2.5"	76.2	63.5	50.8	1.65
4"x1.5"	101.6	38.1	254	2
4"x2"	101.6	50.8	203.2	2
4"x2.5"	101.6	63.5	152.4	2
4"x3"	101.6	76.2	101.6	2
6"x2"	152.4	50.8	406.4	2
6"x3"	152.4	76.2	304.8	2
6"x4"	152.4	101.6	203.2	2

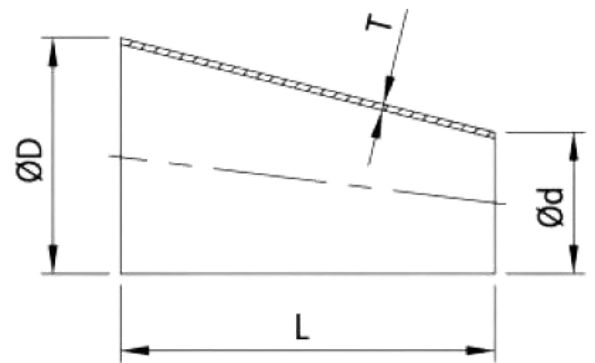

DIN CONCENTRIC & ECCENTRIC REDUCER

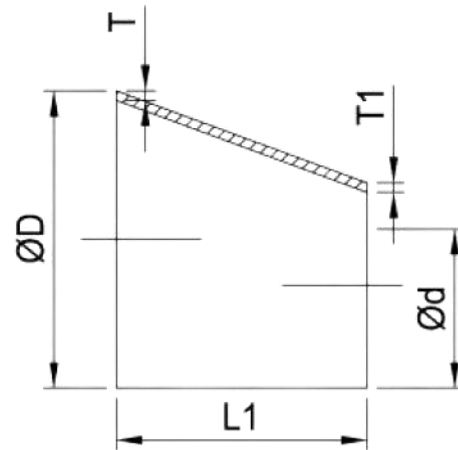
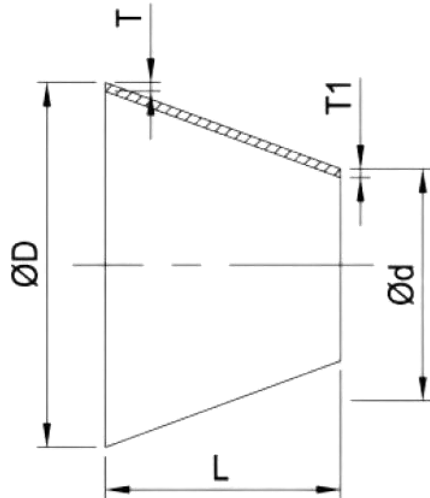

DIN Concentric Reducer

DIN Eccentric Reducer

SIZE	$\varnothing D$	$\varnothing d$	T	L	L1	T1
32x25	34	28	1.5	25	16.5	1.5
40x25	40	28	1.5	23	33	1.5
40x32	40	34	1.5	23	16.5	1.5
50x25	52	28	1.5	27	66	1.5
50x32	52	34	1.5	28	49.5	1.5
50x40	52	40	1.5	27	33	1.5
65x25	70	28	1.5	35	75	1.5
65x40	70	40	2	39	77	1.5
65x50	70	52	2	29	44	1.5
80x50	85	52	2	45	85	1.5
80x65	85	70	2	33	41.2	2
100x50	104	52	2	50	137.5	1.5
100x65	104	70	2	44	93.5	2
100x80	104	85	2	60	52.5	2

HOSE FERRULE ADAPTER & TUBE CAP

Application- Used to connect hoses to a ferrule with just a hose clip for low pressure applications

Size Availability- 0.5" to 4"

Material- SS 304 or SS 316L

Hose Ferrule Adapter

SIZE	ØA	ØB	ØC	L
0.5"	9.5	13.7	25	38
1"x0.5"	9.5	13.7	50.5	38
0.75"	15.8	21.4	25	38
1"x0.75"	15.8	21.4	50.5	38
1"	20.6	25.4	50.5	43
1.5"	33.2	38.1	50.5	43
2"	46	50.8	64	58.7
2.5"	58.7	63.5	77.5	59.5
3"	72	76.2	91	78.6
4"	97.6	101.6	119	85.5

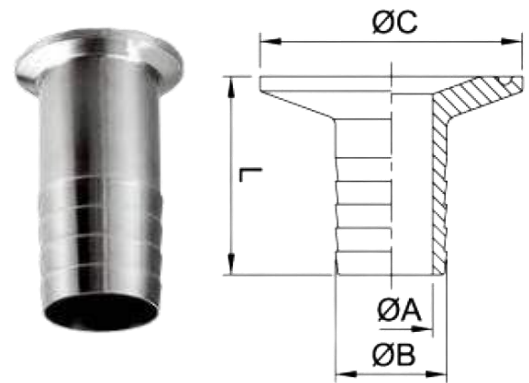

Tube Cap

SMS/3A	OD	DI	DIN	OD	ID
0.5"	12.7	9.4	-	-	-
0.75"	19.05	15.75	-	-	-
1"	25.4	22.1	DN25	29	26
-	-	-	DN32	35	32
1.5"	38.1	34.8	DN40	41	38
2"	50.8	47.5	DN50	53	50
2.5"	63.5	60.2	DN65	70	66
3"	76.2	72.9	DN80	85	81
4"	101.6	97.4	DN100	104	100
-	-	-	DN125	129	125
-	-	-	DN150	154	150

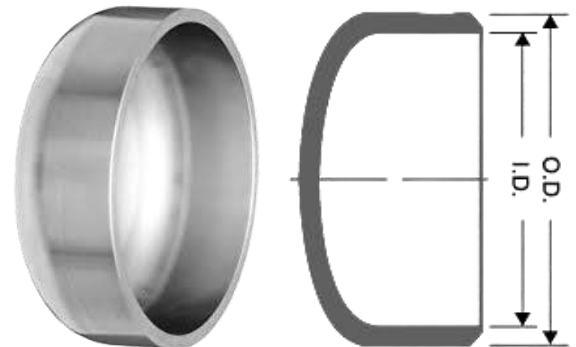

PIPE SUPPORT

Application- Our Dairy **Pipe Supports** are designed to hang Food Grade Pipes. They come in **Bolted Type** and **Wing Nut Type**.

Size Availability- 0.5" to 8"

Material- SS 304

TH-1 Pipe Support

SIZE	ϕA	L
1"	25.4	66
1.5"	38.1	76
2"	50.8	90
2.5"	63.5	105
3"	76.2	120
4"	101.6/104	146
6"	152.4	-

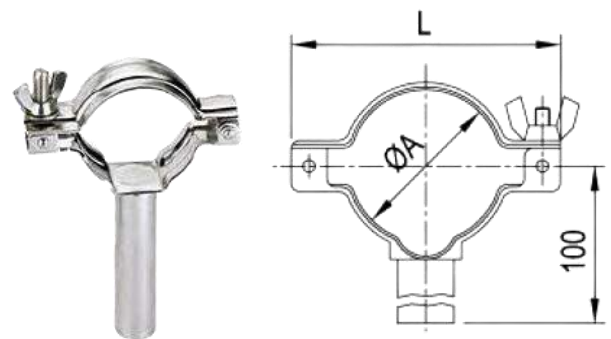

TH-5 Pipe Support

SIZE	$\phi A1$	H	ϕC
0.5" / DN10	13	45	8
0.75" / DN15	19	45	8
1" / DN25	25.4	45	8
1.25" / DN32	34	51.5	10
1.5" / DN40	38.1	51.5	10
2" / DN50	51	58	12
2.5" / DN65	63.5	64	12
3" / DN80	76.1	70.5	15
4" / DN100	101.6	60	15
5" / DIN 125	129	60	15
6" / DIN 150	154	60	15
8" / DIN 200	204	60	15
10" / DIN 250	254	60	15
12" / DIN 300	306	60	15

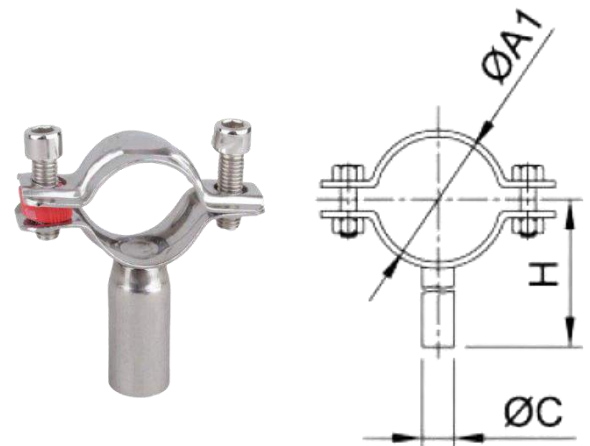

LEVEL GAUGE & SAMPLE COCK VALVE

Level Gauge Valve with Ferrule End

Application- Used to detect the level of liquid inside a storage tank.

Size Availability- 1"

Material Availability- SS 316L

Connection Availability- Ferrule End



Upper Valve



Lower Valve

Sample Cock Valve with Ferrule End

Method of Operation- Turning the handle allows collection of samples.

Size Availability- 1"

Material Availability- SS 316L

Connection Availability- Ferrule End

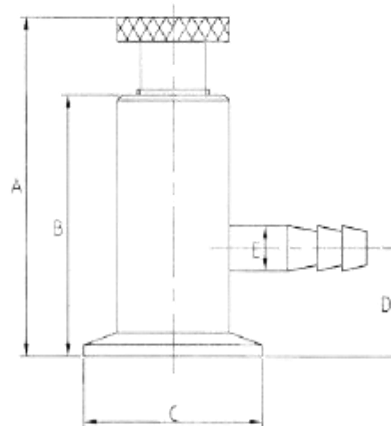

Size	A	B	C	D	E
1"	91.5	70	50.5	29	12
1.5"	91.5	70	50.5	29	12

SANITARY THREE-PIECE BODY BALL VALVE



Method of Operation-

Turning the handle turns the valve ball either parallel or perpendicular to the flow to control or shut off flow. Can be mounted to most commercial actuators due.

Size Availability- 0.5" to 4"

Material Availability- Body in SS 304 and SS 316L, Gasket in PTFE

Connection Availability- Weld Ends, Ferrule Ends

THREE-PIECE BODY BALL VALVE

No.	Part Name	Material
1	Body	ASTM A351 CF8M
2	Cap	ASTM-A351 CF8M
3	Hex Nut	304
4	Bolt	304
5	Seat	PTFE
6	Ball	A351 CF8M
7	Stem	316
8	Stem Packing	PTFE
9	Ring	PTFE
10	O-Ring	Viton
11	Thrust Washer	PTFE
12	Gasket	PTFE
13	Butterfly Spring	304
14	Hex Nut	304
15	Hex Nut	304
16	Washer	304
17	Bolt	304
18	Butterfly Spring	304
19	Handle	304
20	Handle Nut	304
21	Lock Washer	304
22	Handle Cover	Plastic
23	Stop Pin	304

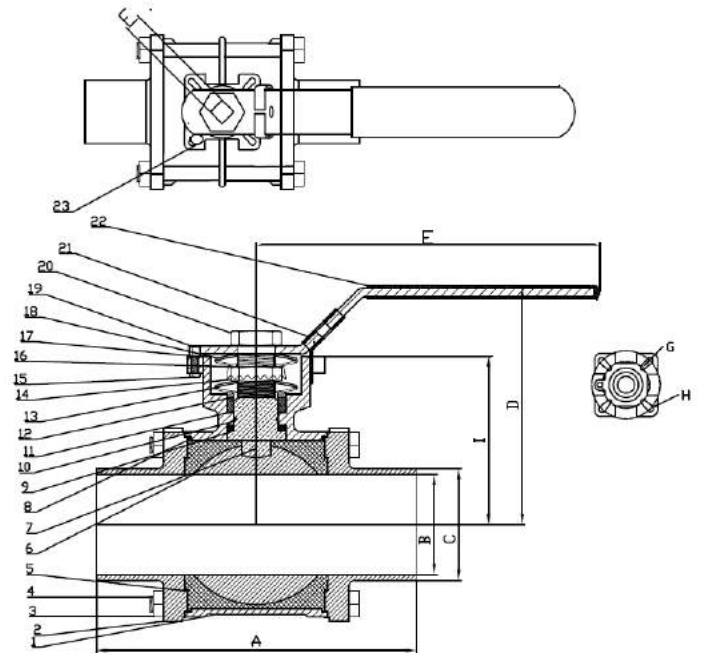

Three-Piece Body Ball Valve Ferrule & Weld Ends

Size	A	B	C Weld	C Ferrule	D	E	F	G	H	I	Torque
0.5"	90.5	9.4	12.7	25.2	64	131	9	F03	F04	37	4~10
0.75"	103.4	15.75	19.5	25.2	68	131	9	F03	F04	43	4~10
1"	114.2	22.1	25.4	50.5	86	169	11	F04	F05	51	5~15
1.5"	136.7	34.8	38.1	50.5	122.5	213	14	F05	F07	71	10~25
2"	153.2	47.5	50.8	64	122.5	213	14	F05	F07	79	15~30
2.5"	167.3	60.2	63.5	77.5	139.5	213	14	F05	F07	94	20~35
3"	192.3	82.9	76.2	91	165	320	17	F07	F10	109.5	40~65
4"	239.5	97.4	101.6	119	177	320	17	F07	F10	123	40~80

TWO-PIECE BODY BALL VALVE

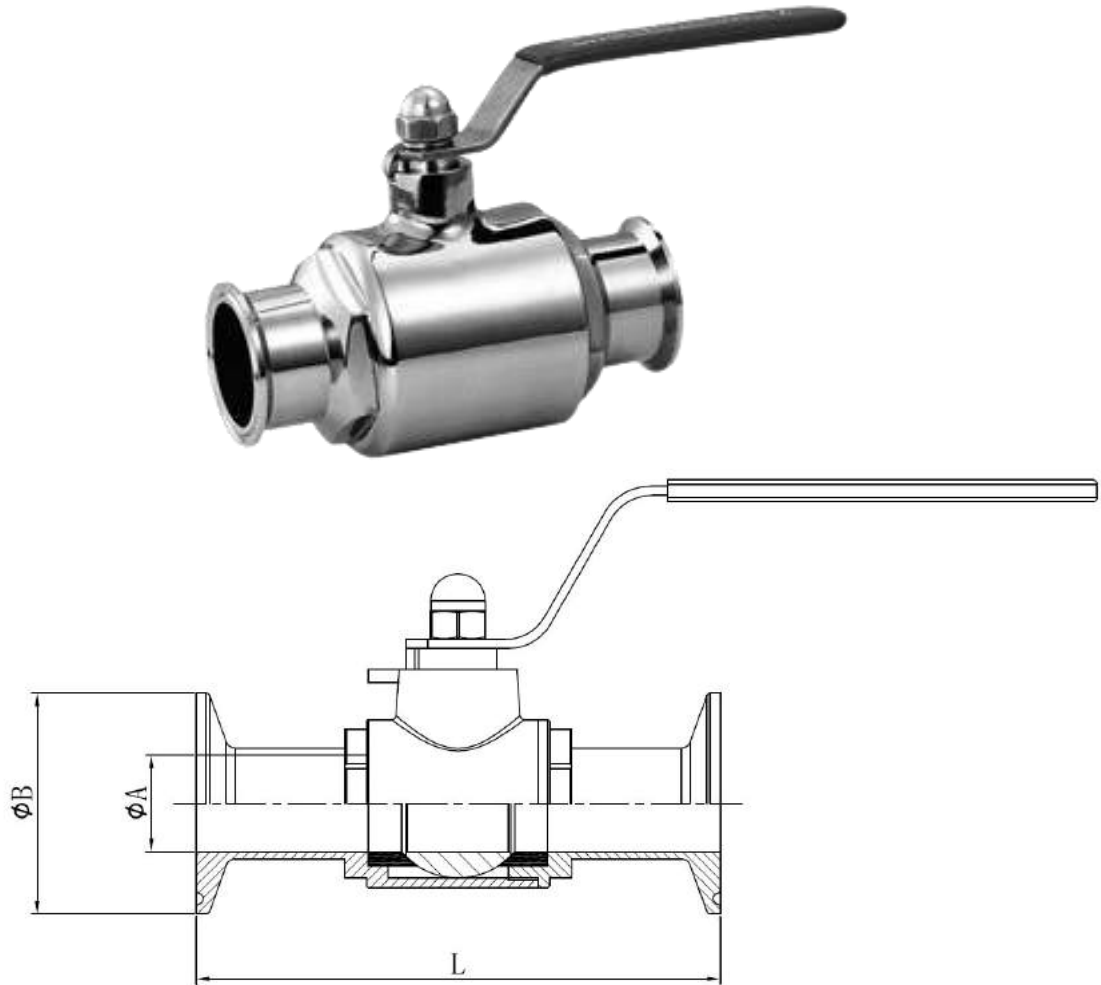

Two-Piece Body Ball Valve

Size	ϕA	ϕB	L
0.5"	9.4	12.7	74
0.75	15.8	25	99.5
1"	22.1	50.5	110
1.5"	34.8	50.5	134
2"	47.5	64	156.5
2.5"	60.2	77.5	170
3"	72.9	91	195
4"	97.4	119	240

BUTTERFLY VALVE



Method of Operation-

Turning the handle turns the disc either parallel or perpendicular or anywhere in between to control the flow.

Can be equipped with an Actuator to be controlled by air, spring, or electric.

Size Availability- 0.5" to 4", DN25 to DN100

Material Availability- Body in SS 304 and SS 316L, Gaskets in EPDM, Silicone, or BUNA

Connection Availability- Weld Ends, Ferrule Ends, other Sanitary Union connections

Pressure Rating- Up to 9.5 bar, decreases along with size

Torque Required for Full Open and Close-

1"	1.5"	2"	2.5"	3"	4"	6"
9.8Nm	9.8Nm	13Nm	15Nm	20Nm	30Nm	70Nm

Components List:

No.	Name
1	Knob
2	Steel Bar
3	Spring ST.ST
4	ST.ST
5	Holder
6	Body
7	Disc
8	EPDM Rubber Seat
9	Screw Bolt

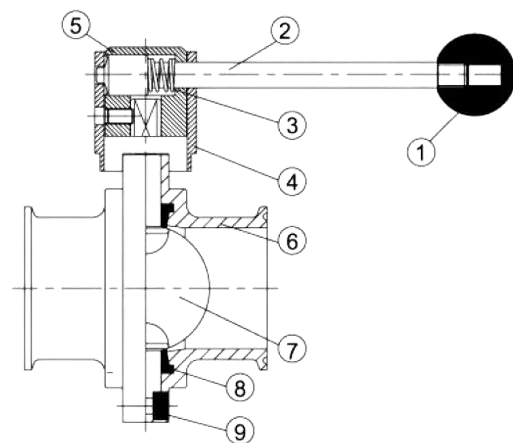

BUTTERFLY VALVE

Butterfly Valve with Weld Ends

Size	øA	øB	D	øE	L
0.5"	9.5	12.7	23	79	49.5
0.75	15.8	19.50	23	79	49.5
1"	22.1	25.4	23.5	79	49.5
1.5"	34.8	38.1	23.5	85	52.5
2"	47.5	50.8	26	100	60
2.5"	60.2	63.5	27	115	67.5
3"	72.2	76.2	28	127	73.5
4"	97.6	101.6	30	156	88
6"	146.8	152.4	40.5	215	142

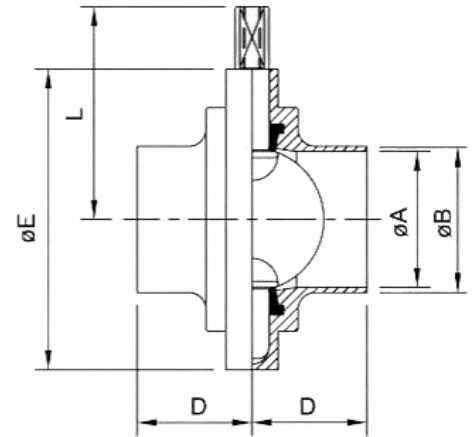

Butterfly Valve with Ferrule Ends

Size	øA	øB	D	øE	L
0.5"	9.5	25.2	35	79	49.5
0.75	15.8	25.2	35	79	49.5
1"	22.1	50.5	35	79	49.5
1.5"	34.8	50.5	35	85	52.5
2"	47.5	64.0	37	100	60
2.5"	60.2	77.5	38	115	67.5
3"	72.2	91.0	39	127	73.5
4"	97.6	119.0	45	156	88
6"	146.8	166.8	62.2	215	142

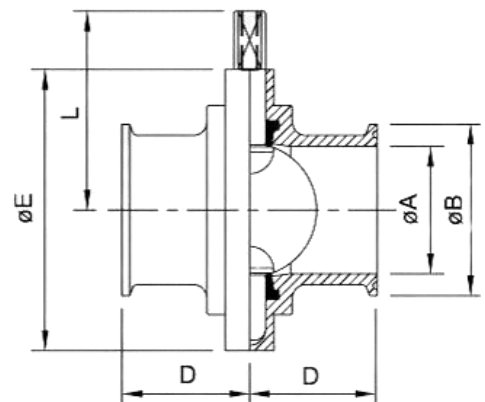

DIN Butterfly Valve with Weld Ends

Size	øA	øB	D	øE	L
DN25	26	29	23.5	79	49.5
DN32	32	35	23.5	82	48.5
DN40	38	41	25	92	52.5
DN50	50	53	26	106	63.5
DN65	66	70	28	127	71.5
DN80	81	85	29	140	78.5
DN100	100	104	30	156	87.5

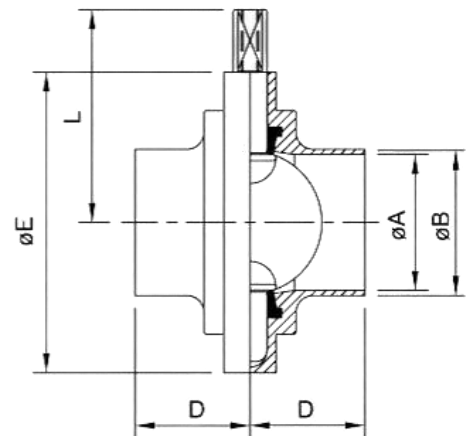

BUTTERFLY VALVE ACTUATOR



**Without Solenoid Valve
and Limit Switch**



**With Solenoid Valve
and Limit Switch**

Operation Instructions:

- 1) Signal Transfer:
 - a) 10-30VDC proximity switch 1 or 2pcs (PNP or NPN),
 - b) or 3A 125 VAC, 30 VDC micro switch 2 pcs.

- 2) Air/Air (double effect) actuator or Air/Spring (single effect).

Shut Off Time (seconds)	1.5
Weight (kg)	2.5
Operating Air Pressure 6Kg/cm²	5-9 bar
Air Consumption at 5 bar	0.266 liters
Material	SS 304
Max Output Torque (N/M)	20

NON-RETURN VALVE / CHECK VALVE

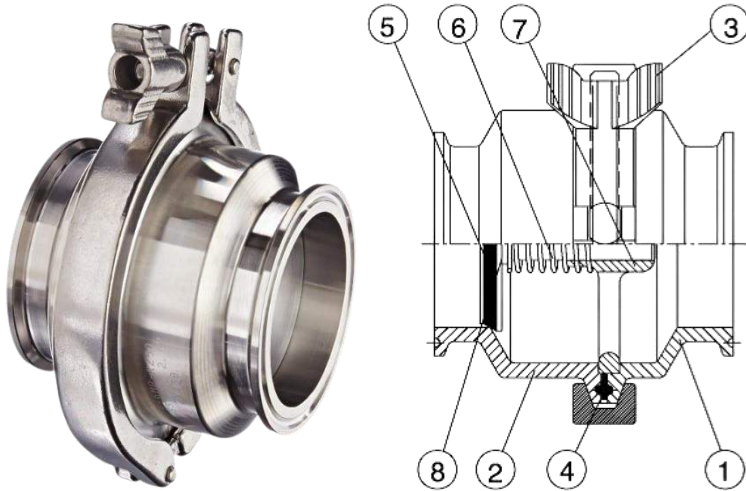

Components List:

No.	Name
1	Short Body
2	Long Body
3	Clamp
4	13 PG
5	Seal Ring
6	ST.ST Spring
7	Flow Support Plate
8	Disc

The sanitary **Check Valve** contains a stainless-steel body which houses a disc supported by a spring. When enough pressure is applied, the disc opens and allows product to flow through.

Method of Operation-

Works automatically when enough flow pressure pushes the disc so that the product flows through.

When pressure is not high enough, the disc remains pushed shut so that the product does not flow through.

Size Availability- 0.5" to 4"

Material Availability- Body in SS 316L, Gaskets in EPDM

Connection Availability- Weld Ends, Ferrule Ends

Pressure to Open Valve- 0.5 psi to 3 psi, depending on size

Opening Pressure (PSI)							
0.5"	0.75"	1"	1.5"	2"	2.5"	3"	4"
0.5	0.5	3	1.6	0.6	1.3	0.8	0.9

NON-RETURN VALVE / CHECK VALVE

Pressure required for opening the valve fitted in a vertical pipe (max pressure- 10 bar):

Spring Check Valve Pressure Drop

(fig. 3)

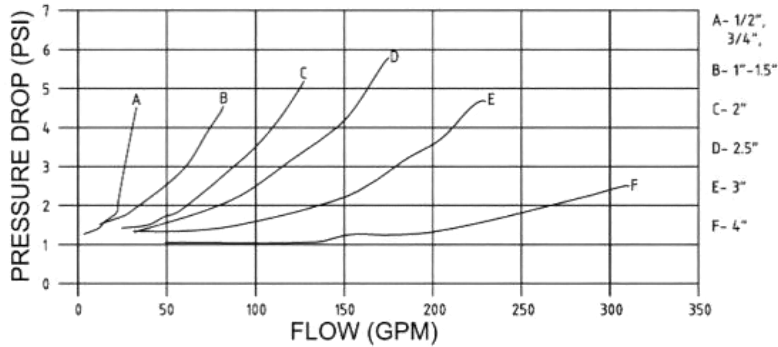

Note:
For the diagram the following applies:
Medium: Water(20°C)

Check Valve with Weld Ends

Size	øA	øB	øC	L1	L2
0.5"	50.5	12.7	9.4	35	22
0.75"	64	19.05	15.75	35	22
1"	64	25.4	22.1	47.5	30.5
1.5"	77.5	38.1	34.8	50	30
2"	91	50.8	47.5	58	30
2.5"	106	63.5	60.2	58	37
3"	119	76.2	72.9	70	36
4"	144.5	101.6	97.6	68	37

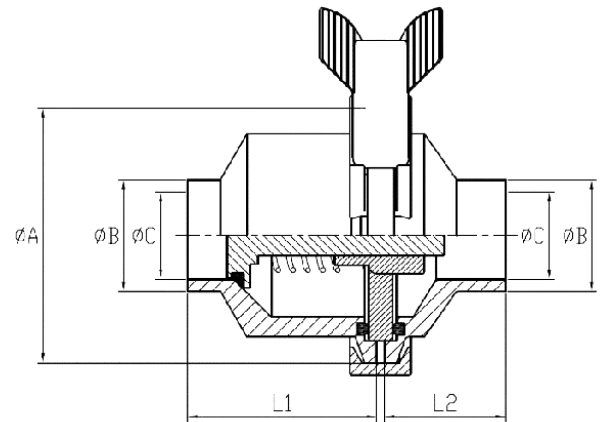

Check Valve with Ferrule Ends

Size	øA	øB	øC	L
0.5"	50.5	25	9.5	88.9
0.75"	64	25	15.8	88.9
1"	64	50.5	22.1	104.8
1.5"	77.5	50.5	34.8	115.9
2"	91	64	47.5	128.6
2.5"	106	77.5	60.2	136.5
3"	119	91	72.9	155.6
4"	144.5	119	97.6	206.4

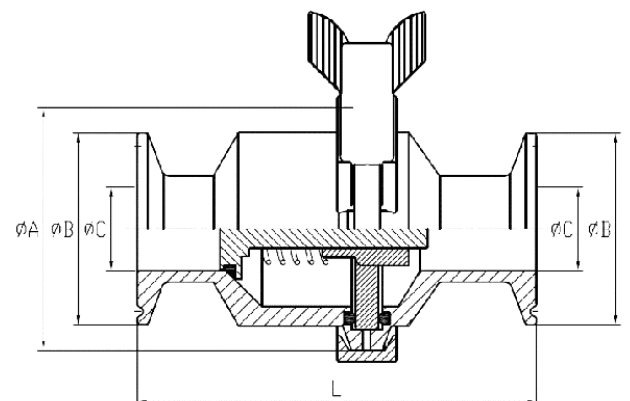

Diaphragm Valve

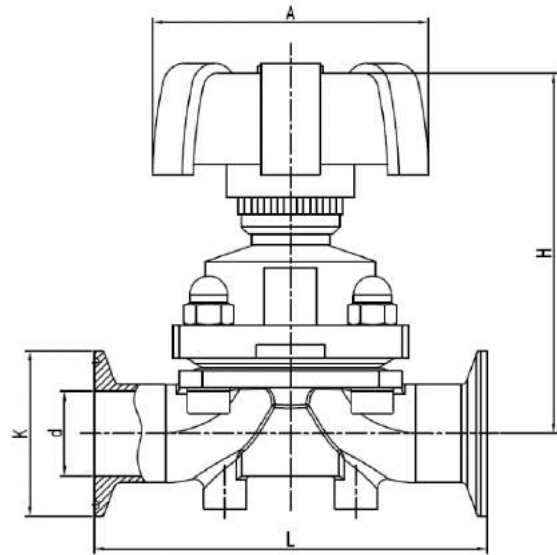

Diaphragm Valve with Ferrule Ends and Weld Ends

Size		L	A	K x d Ferrule	K x d Weld	H
0.5"	DN10	89	33	25 x 9.4	12.7 x 9.4	70
0.75	DN15/20	109	58	25 x 15.8	19.1 x 15.8	70
1"	DN25	127	90	50.5 x 22.1	25.4 x 22.4	119
1.25"	DN32	159	90	50.5 x 28.5	31.8 x 28.5	139
1.5"	DN40	159	114	50.5 x 34.8	38.1 x 34.8	139
2"	DN50	190	140	64 x 47.5	50.8 x 47.5	150
2.5"	DN65	216	140	77.5 x 60.2	63.5 x 60.2	162
3"	DN80	256	140	91 x 72.9	76.2 x 72.9	170
4"	DN100	350	140	119 x 97.4	101.6 x 97.4	

PRESSURE RELIEF VALVE

The sanitary **Pressure Relief Valve** contains a disc supported by springs. When enough pressure is applied, the disc opens and allows unwanted pressure to flow through.

Method of Operation-

Works automatically when enough pressure pushes valve disc to release pipe line air pressure.

Size Availability- 1" to 4"

Material Availability- Body in SS 304 and SS 316L

Connection Availability- Weld Ends, Ferrule Ends

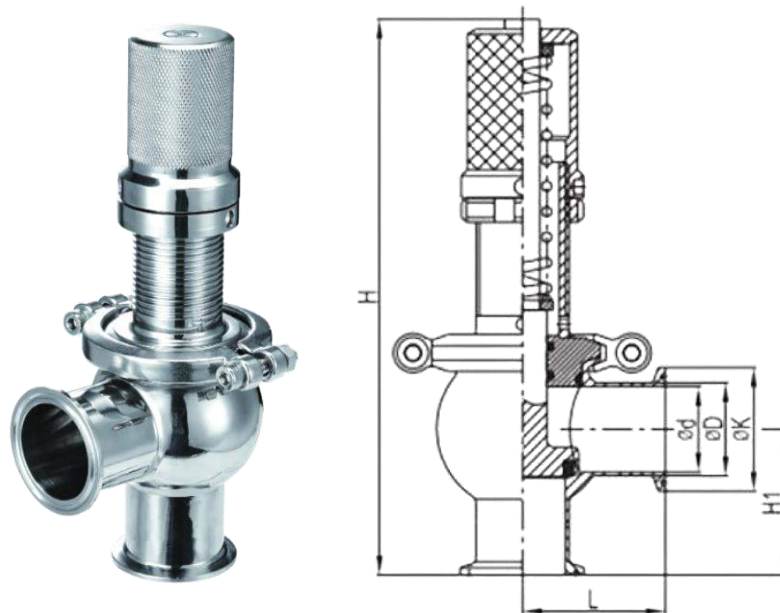

Size	ød	øD	øK	H1	L	H
1"	22.4	25.4	50.5	61	61	227
1.5"	35.1	38.1	50.5	58	59	227
2"	47.8	50.8	64	66	66	270
2.5"	59.5	63.5	77.5	77	77	318
3"	72.2	76.2	91	97	97	351
4"	97.6	101.6	119	127	135	399

VACUUM RELIEF VALVE



The sanitary **Vacuum Relief Valve** contains a disc supported by springs. When enough pressure is applied, the disc opens and allows unwanted pipe line air to flow through.

Method of Operation-

When enough pressure pushes valve disc to release pipe line air pressure.

Similarly, when there is enough vacuum pressure present, the disc is pushed in the opposite direction to relief pipe line vacuum pressure.

Size Availability- 2.5"

Material Availability- Body in SS 304 and SS 316L

Connection Availability- Weld End

Pressure to Open Valve- 0.02 bar Opening Pressure or 0.01 bar Vacuum Pressure

Components List:

No.	Item Name	Material	Qty.
1	Male Part	AISI 304L	1
2	Nut	AISI 304L	1
3	Taper Blank	AISI 304L	1
4	Locking Device	PTFE	1
5	Upper Disc	AISI 304	1
6	Cap	AISI 304	1
7	Ball	AISI 304	1
8	Vacuum Spring	AISI 304	1
9	Screw 3Max8	AISI 304	2

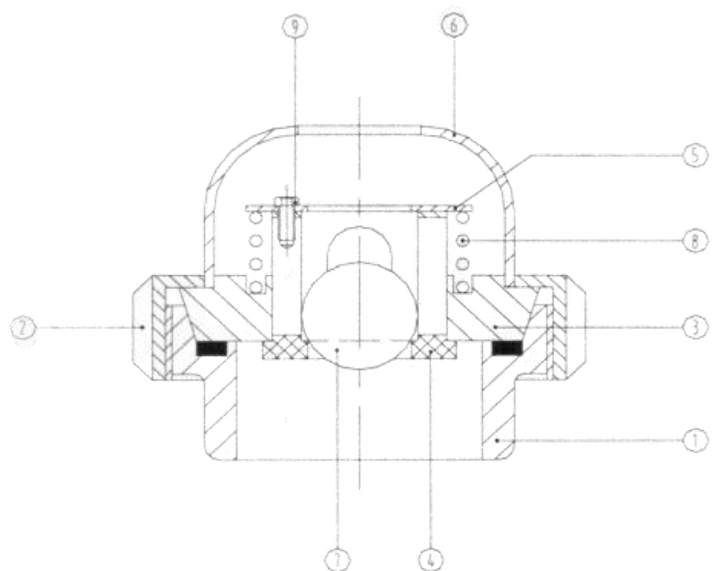

THREE WAY PLUG VALVE



Method of Operation-

Turn the handle rotates the conical plug inside the valve to divert and shut off flow.

The only Sanitary Valve to achieve shut off and divert flow at the same time.

Size Availability- 0.5" to 4"

Material Availability- Body in SS 304 and SS 316L, Gaskets in EPDM or BUNA

Connection Availability- Weld Ends, Ferrule Ends, other Sanitary Union connections

Pressure Rating- Up to 1.7 bar, decreases along with size

Three Way Plug Valve with Weld/Male/Ferrule Ends

OD 3A	OD DIN	A Weld	A Male	A Ferrule	B	D
1"	DN25	66.3	95.3	94.9	26	139.19
1.5"	DN40	85.1	118.1	113.7	35	139.19
2"	DN50	114.2	149.2	142.8	45	143.01
2.5"	DN65	132	172	160.6	55	143.69
3"	DN80	168.6	213.6	197.2	70	143.81
4"	DN100	206.3	260.3	234.9	75	174.21

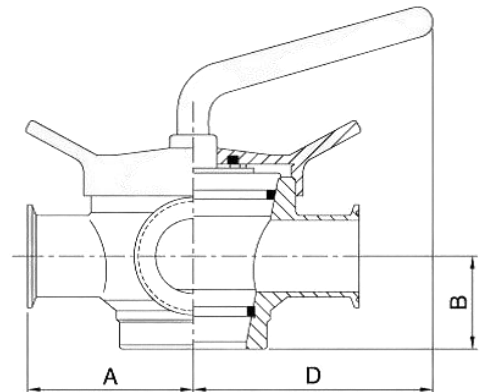

INLINE SIGHT GLASS

Application- The clear tube allows operators an easy inspection of the product flow.

Size Availability- 1" to 4"

Material Availability- SS 316L body houses a Borosilicate Glass Tube

Connection Availability- Weld Ends, Ferrule Ends

Inline Sight Glass with Weld Ends

Size	ØA	ØB	ØC	L
1"	22.1	25.4	79	130
1.5"	34.8	38.1	85	128
2"	47.5	50.8	100	133
2.5"	60.2	63.5	115	131
3"	72.9	76.2	127	134
4"	97.6	101.6	156	135

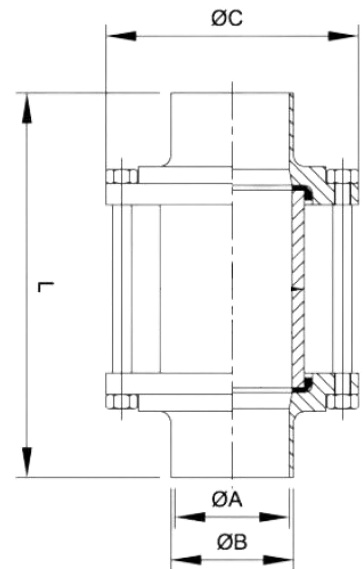

Inline Sight Glass with Ferrule Ends

Size	ØA	ØB	ØC	L
1"	22.1	50.5	79	153
1.5"	34.8	50.5	85	151
2"	47.5	64	100	155
2.5"	60.2	77.5	115	153
3"	72.9	91	127	156
4"	97.6	119	156	165

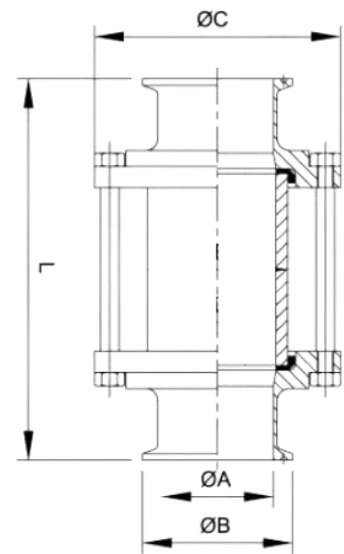

TANK SIGHT GLASS

Method of Operation-

Installed by welding on a tank, it provides a means of viewing the insides.

Commonly used to observe liquid levels and contents of a tank.

Size Availability- 1" to 4", DN100 & DN150

Material Availability- Body in SS 316L, Gaskets in EPDM, Teflon, Silicone

Pressure Rating- up to 10 bar

SMS Union Tank Sight Glass

SIZE	øD	øD5	øT
1"	25.4	50	1.25
1.5"	38.1	60	1.25
2"	50.8	72	1.25
2.5"	63.5	98	1.5
3"	76.1	114	1.5
4"	101.6	150	2

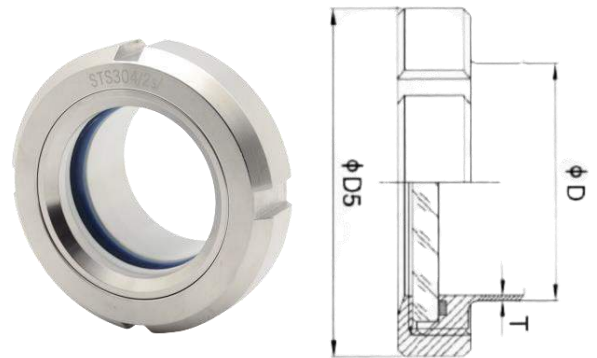

Flange Tank Sight Glass

Item	Description
1	Welding Flange
2	Cover Flange
3	Gasket
4	Sight Glass Disc
5	Nut
6	Screw

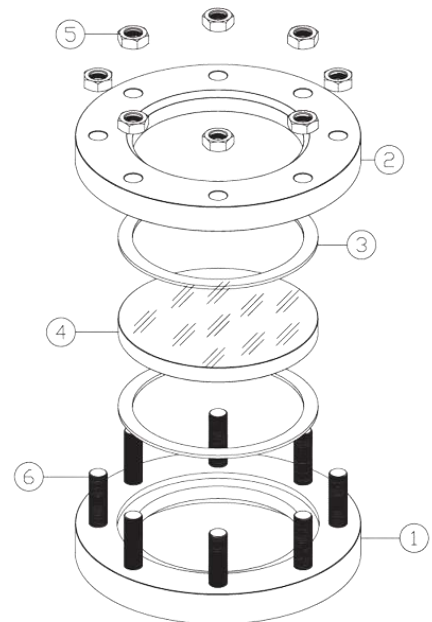

SANITARY CLEANING SPRAY BALL

Application- Provides an easy means of rinsing tanks.

Size Availability- 1" to 2.5"

Material Availability- Body in SS 304 and SS 316L

Connection Availability- Bolted End, BSP End, Ferrule End

Bolted Static Spray Ball

Size	A	Q
1"	95	63
1.5"	110	76
2"	125	91
2.5"	135	100

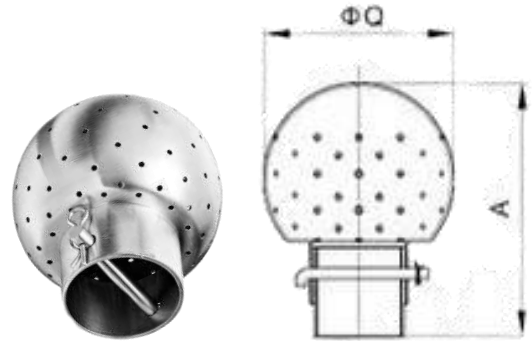

Size	Pressure (bar)	Cleaning Radius (M)	360°/180° Fluxation (m3/h)
1"	2.5	1 – 1.25	17/10
1.5"	2.5	1.25 – 1.75	23/17
2"	3.5	2 – 3	55/38
2.5"	3.5	3 – 3.5	58/41

Bolted Rotary Spray Ball

Size	A	Q
1"	135	53
1.25"	137	53
1.5"	137	53
2"	168	63
2.5"	190	76

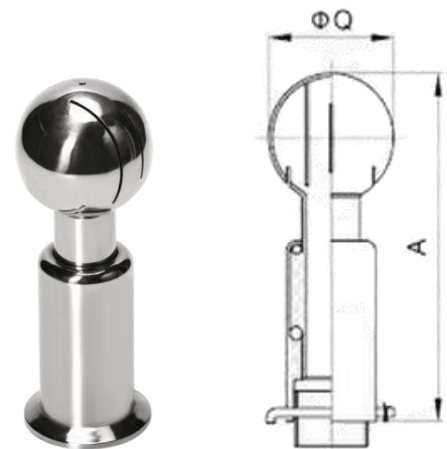

Size	Pressure (bar)	Cleaning Radius (M)	Fluxation (m3/h)
1" – 1.5"	2	1.25	12
2"	2	1.5	38
2.5"	2	2	38

ROUND MANHOLE COVER

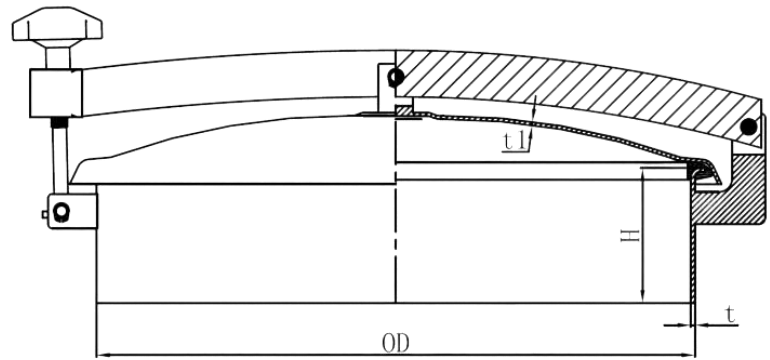

Round Non-Pressure Manhole Cover (0 – 0.1 Bar)

Size	Ø200	Ø300	Ø400	Ø420	Ø450	Ø460	Ø500	Ø600
OD	200	300	400	420	450	460	500	600
T	3	3	3	2.5	3	2.5	3	3
H	100	100	100	100	100	100	100	100
T1	2.5	2.5	2.5	2.5	2.5	2.5	2.5	2.5

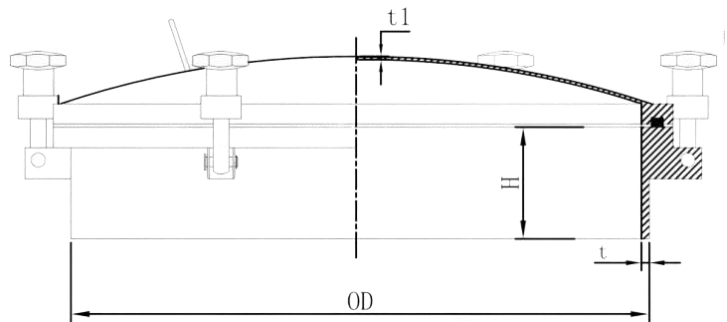

Round Pressure Manhole Cover (-1 to 3 Bar)

Size	Ø200	Ø300	Ø400	Ø450	Ø500	Ø600
OD	206	306	406	456	506	605
T	3	3	3	3	3	3
H	100	100	100	100	100	100
T1	3	3	3	3	3	3
Handles	4	5	6	6	6	8

OVAL MANHOLE COVER

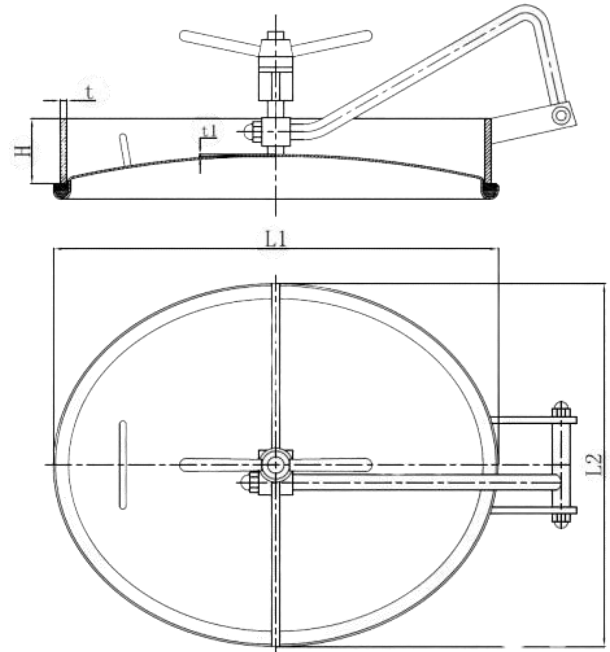

Oval Manhole Cover (-1 to 3 Bar)

Size (L1 x L2)	430mmx 330mm	435mmx 335mm	450mmx 350mm	530mmx 430mm	535mmx 435mm	635mmx 525mm
T	8	8	8	8	10	10
H	80	80	80	80	80	80
T1	2.5	2.5	3	3	3	3

FOOD GRADE FLEXIBLE HOSE

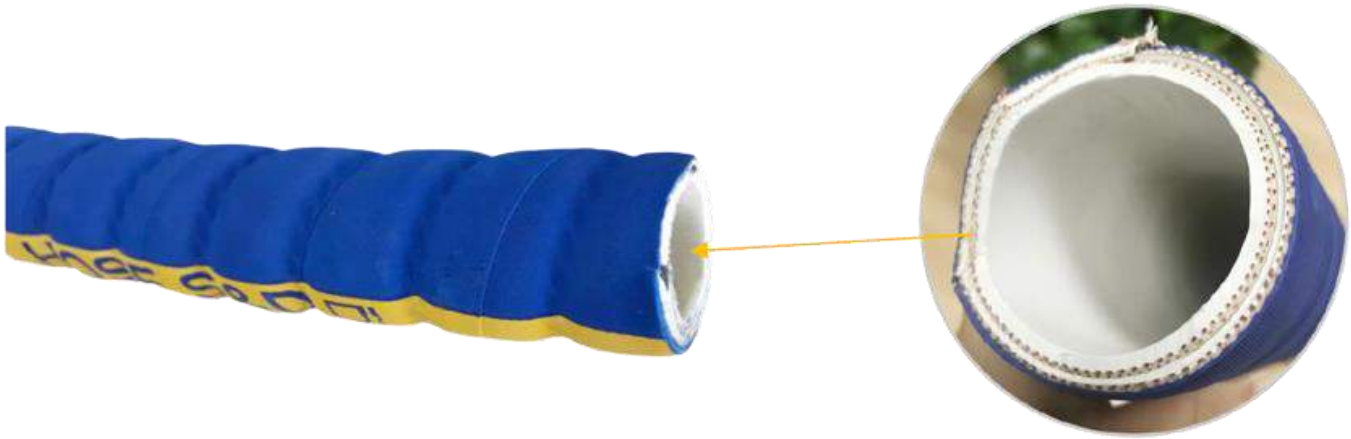

Application- Versatile suction and delivery hose. Specifically designed to convey a wide range of chemicals (solvents and corrosive liquids), pharmaceutical, beverage, dairy, alcohol and other alimentary products.

Tube- UHMWPE (Ultra High Molecular Weight Polyethylene)

Cover- Corrugated black or blue EPDM compound. (Abrasion and ozone resistant)

Reinforcement- Multiple textile plies with dual helix wire.

Temperature Range- -40 °C ~ +120 °C

Standard/Approval- FDA 21 CFR 177.1520

Size	ID (mm)	OD (mm)	Bending Radius (mm)	Working Pressure (bar)
0.75"	19.05	31	100	13.8
1"	25.4	38.05	130	13.8
1.5"	38.1	52.5	210	13.8
2"	50.8	66.5	280	13.8
2.5"	63.5	83	370	13.8
3"	76.2	95	440	13.8
4"	101.6	124	600	13.8

FOOD GRADE HOSE CONNECTIONS

Application- Securely attaches the hose to the desired connections.

Size Availability- 0.75" to 4"

Material Availability- Safety Clamp in SS 316, Hose Collar in SS 304, Hose Tail in SS 316L

Connection Availability- Weld End, Ferrule End, SMS Liner End, SMS Male Part End



Hose Collar



Safety Clamp



Hose Tail

Hose Tail with Ferrule End

Size	ØA	ØB	L
0.75"	25.2	19	60
1"	50.5	25	63
1.5"	50.5	38	67
2"	64	50	77.5
2.5"	77.5	63	91.5
3"	91	76	105.7
4"	119	102	117.5

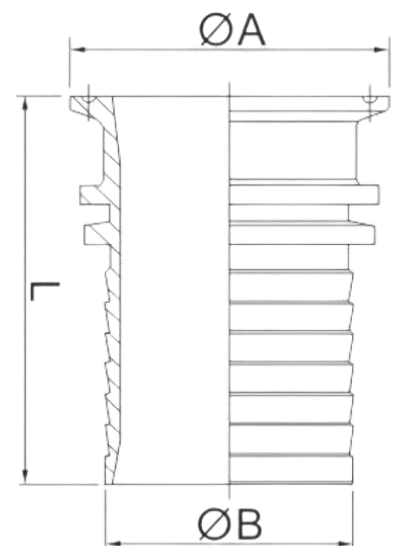

FOOD GRADE HOSE CONNECTIONS

Hose Tail with SMS Liner End

Size	ØA	ØB	L
1"	35.5	25	61.5
1.5"	55	38	63
2"	65	50	79.5
2.5"	80	63	97.5
3"	93	76	113.5
4"	118	102	124.5

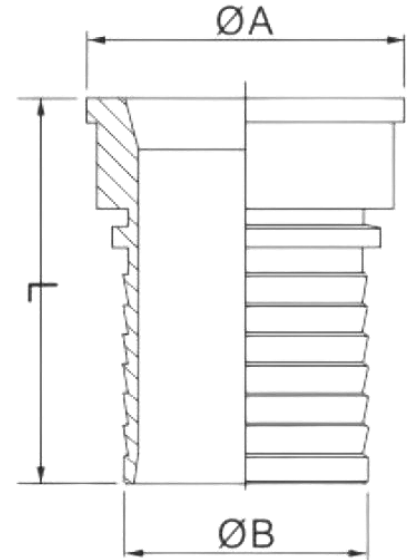

Hose Tail with SMS Male Part End

Size	ØA	ØB	L
1"	40 x 1/6	25	69
1.5"	60 x 1/6	38	74
2"	70 x 1/6	50	80.5
2.5"	85 x 1/6	63	106.5
3"	98 x 1/6	76	120.5
4"	124 x 1/4	102	130

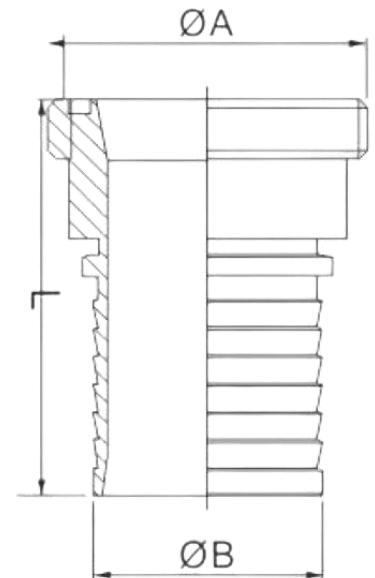

FOOD GRADE WATER SPRAY GUN



Application- By depressing the lever, the desired jet strength can be adjusted continuously from a fine spray mist to a concentrated jet. Suited for gentle and effective cleaning in practically any operation.

Body- Brass and stainless steel

Cover- Shock, heat, and cold by alkali-and an acid-resistant rubber jacket

Connection- 0.5" BSPP thread

Pressure- Up to 24 bar

Temperature- Up to 50C

Flow Rate- litres/minute at 5 bar

SANITARY FILTER

Application- The internal cartridge with perforated plate and wire mesh eliminates contaminants.

Connection Size Availability- 1" to 4"

Housing Types- Inline Strainer, Angle Strainer, Wye

Mesh Size Availability- 20 to 500 mesh

Material Availability- Body and cartridge in SS 304 or SS 316L

Connection Availability- Weld Ends, Ferrule Ends

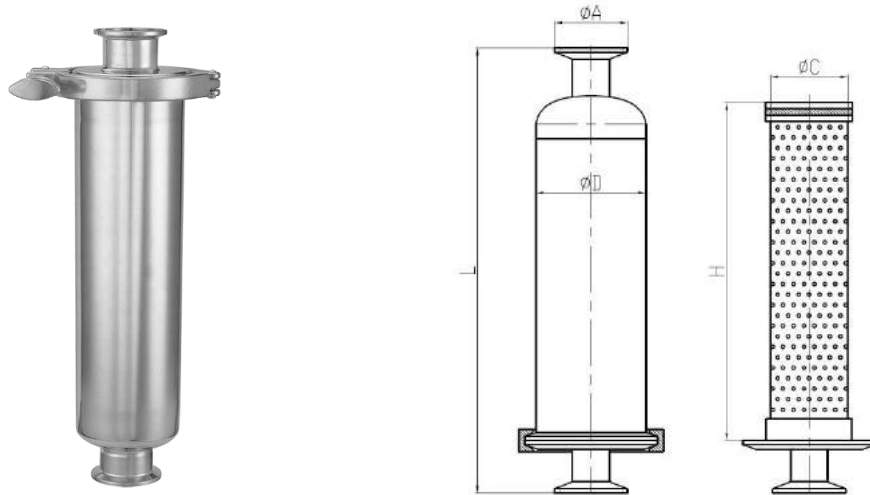

Inline Filter with Ferrule Ends and Weld Ends

Size	A Ferrule	A Weld	L	D	C	H
1"	50.5	25.4	306	76	47	210
1.5"	50.5	38.1	306	76	47	210
2"	64	50.8	406	89	60	290
2.5"	77	63.5	506	102	72	400
3"	91	76.2	556	114	88	450
4"	119	101.6	666	159	120	550

SANITARY FILTER

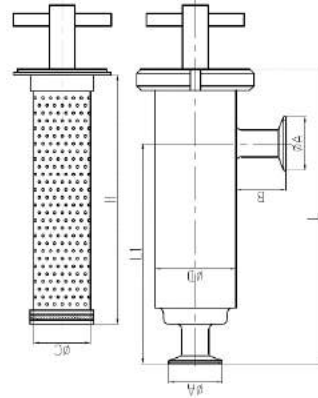

Angle Filter with Ferrule Ends and Weld Ends

Size	A Ferrule	A Weld	L	L1	D	B	C	H
1"	50.5	25.4	306	212	76	40	46	256
1.5"	50.5	38.1	306	212	76	40	46	256
2"	64	50.8	406	285	89	40	58	356
2.5"	77.5	63.5	506	386	102	40	71	456
3"	91	76.2	556	422	114	45	80	516
4"	119	101.6	666	500	159	50	117	626

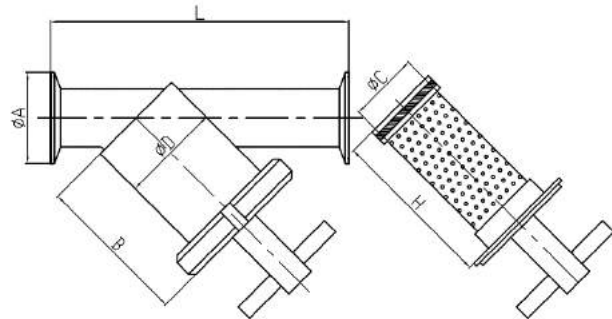

Wye Filter with Ferrule Ends and Weld Ends

Size	A Ferrule	A Weld	L	D	B	C	H
1"	50.5	25.4	170	45	110	30	98
1.5"	50.5	38.1	205	63	130	40	118
2"	64	50.8	225	76	150	51	138
2.5"	77.5	63.5	275	89	185	71	173
3"	91	76.2	310	102	205	71	193
4"	119	101.6	390	133	270	100	258

DAIRY TUBES

Our **Dairy Tubes** are available in ASTM A270 SS 304 and SS 316L.

Available in SMS and DIN Standard (6-meter length).

External Matte Polished, internal pickled with acid and bead removed.



SMS and DIN Dairy Tubes

SMS	OD x Wall Thickness	DIN	OD x Wall Thickness
0.5"	12.7x1.65mm	DN10	13x1.5mm
0.75"	19.05x1.65mm	DN 15	19x1.5mm
-	-	DN 20	23x1.5mm
1"	25.4x(1.25 or 1.65mm)	DN 25	29x1.5mm
-	-	DN 32	35x1.5mm
1.5"	38.1x(1.25 or 1.65mm)	DN 40	41x1.5mm
2"	50.8x(1.25 or 1.65mm)	DN 50	53x1.5mm
2.5"	63.5x1.5mm	DN 65	70x2mm
3"	76.2x1.6mm	DN 80	85x2mm
4"	101.6x2mm	DN 100	104x2mm
-	-	DN 125	129x2mm
-	-	DN 150	154x2mm

How are Dairy Stainless-Steel Tubes different from other stainless-steel pipes?

At first glance, Sanitary Stainless-Steel Tubes look the same as other stainless-steel pipes, even the material composition looks similar. Here is how you can tell the difference.

- To qualify as sanitary, the internal surface has to be polished to at least 150 Grit, much smoother than non-sanitary tubes, but because of low price difference, markets today offer Sanitary Tubes with at least 180 Grit.
- The easiest way to identify Sanitary Tubes is the price. Because all Sanitary Tubes, Fittings and Valves in Malaysia have to be imported, the prices are usually higher than other stainless-steel products.

WHAT IS SANITARY / FOOD GRADE STAINLESS STEEL?

To qualify as food grade, the stainless-steel **surface finish and material composition** has to conform to food grade standards.

Surface Finish:

Food grade /sanitary surface finish usually come in **at least No. 4 finish with 150 grit**. No. 5, 6, 7, 8 are more expensive finishes and are also sometimes use in sanitary applications.



Surface Finish	Description
Mill Finish	
No. 0	Hot rolled, annealed, thicker plates
No. 1	Hot rolled, annealed, passivated
No. 2D	Cold rolled, annealed, pickled, passivated
No. 2B	Same as 2D with additional roller polishing
No. 2BA	Bright annealed 2B
Polished Finish	
No. 3	Coarse abrasive finish
No. 4	Brushed finish
No. 5	Satan finish
No. 6	Matte finish
No. 7	Reflective finish
No. 8	Mirror finish
No. 9	Bead blast finish
No. 10	Heat-colored finish (widely varied)

Material Composition: The below are the American ASTM A270 standards, other food grade stainless steel standards will not be a lot different from it.

Standard / Element %	C max	Mn max	P max	S max	Si max	Ni	Cr	Mo
ASTM A270 SS304 / SS304L	0.08/ 0.035b	2	0.045	0.03	1	8-11	18-20	-
ASTM A270 SS316(1.4401) / SS316L(1.4404)	0.08/ 0.035b	2	0.045	0.03	1	10-14	16-18	2-3

Gasket/Seal Material Characteristics

Material	BUNA	EPDM	VITON	TEFLON	SILICONE
Temp(°C)	-51~121°C	-51~149°C	-40~232°C	-40~232°C	-40~232°C
Acid	Good	Good to Excellent	Good to Excellent	Good to Excellent	Poor to Good
Alkali	Fair to Good	Fair to Good	Poor to Good	Excellent	Poor to Fair
Fats/Oils	Good to Excellent	Poor	Good to Excellent	Excellent	Poor to Good
Taste	Good	Good	Good	Excellent	Good
Odor	Good	Good	Good	Excellent	Good
Abrasion Resistance	Excellent	Good	Good	Fair	Good

- Poor ➤ Fair ➤ Good ➤ Excellent

NKE Flow Components Supply imports and stocks Food Grade Stainless Steel Tubes, Fittings, Valves, and other Sanitary Components for the local food, beverage, and pharmaceutical industry.

You need **Quality**, so we provide **Material Certificates!**

You need **Quick Delivery**, so we **Stock Full Range of Sizes!**

You need to **Cut Costs**, so we provide the **Best Prices in Malaysia!**

We Work With

Campbell Cheong Chan Sdn Bhd



Tetrapak (M) Sdn Bhd



Lam Soon Edible Oils Sdn Bhd



Hovid Berhad



Kilang Makanan Mamee Sdn Bhd



Mewah Group

